



ISSN Print : 1656-4707
ISSN Online: 2467-5903

The Palawan Scientist

Volume 11

July 2019

A Research Journal of the Western Philippines University
Aborlan, Palawan
www.wpu.edu.ph



www.palawanscientist.org

The Palawan Scientist, a recipient of a 3-year Commission on Higher Education - Journal Incubation Grant for the year 2017 – 2019, is an annual peer reviewed multi-disciplinary journal published by the Western Philippines University, Palawan, Philippines. It accepts original research articles, reviews, notes and short communications in agriculture, fisheries and aquatic sciences, environment, education, engineering, mathematics, sociology and related disciplines.

Articles published in the Palawan Scientist are indexed in the Emerging Sources Citation Index (Clarivate Analytics), ASEAN Citation Index (ACI), Google Scholar, and Philippine E-Journals. It is under evaluation by the Aquatic Science and Fisheries Abstract (ASFA).

Disclaimer

The Editorial Board of the Palawan Scientist is making all possible efforts to ensure the accuracy of all information, but it does not provide warranties as to the accuracy and or completeness of the information. The opinion and ideas expressed in this publication are by the authors and not necessarily of the publisher. The WPU cannot accept any legal responsibility or liability arising from plagiarism and other errors.

Copyright © 2019, Western Philippines University

Submission of research articles in The Palawan Scientist means that such has not been published before except in a form of abstract in conference proceedings; that the same article is not under consideration for publication in any language elsewhere; that all co-authors if there are has approved its publication in this journal; that all authors transferred the copyright to publisher upon the acceptance and publication of the articles; that the articles will not be published in any form or language without the consent of the copyright.

Cover Photo

The Asian Leaf Turtle *Cyclemys dentata* (top) and the Southeast Asian Box Turtle *Coura amboinensis* (bottom) are the two most common turtle species in Palawan. These species are of diverse ecological and economic importance but habitat degradation and unregulated harvesting are affecting their populations. The International Union for Conservation of Nature (IUCN) has now classified the former as Near Threatened, and the latter as Vulnerable. Both species are semi-aquatic. *Coura amboinensis* are often found in rice paddies, marshes and shallow ponds, while *C. dentata* inhabits rivers, and streams with rocky bottoms. These species are active at night, and individuals crossing on the road traversing their inundated habitats sometimes fall victim to passing vehicles. The paper of Alejandro A. Bernardo Jr. which presented a 6-year observation on turtle road kill incidents in southern Palawan is hoped to raise awareness and find ways to minimize this kind of threat to wildlife (Photos by: Sabine Schoppe).

EDITORIAL BOARD

Editor-in-Chief

Roger G. Dolorosa, PhD
Environmental Science
Western Philippines University

Associate Editors

Liwayway H. Acero, EdD
Educational Management
San Beda College,
Philippines

Allaine T. Baaco, PhD
Environment & Economics
Western Philippines University

Christopher Marlowe A. Caipang, PhD
Aquatic Biosciences
University of San Agustin, Iloilo City,
Philippines

Gerard G. Dumancas, PhD
Analytical Chemistry
Louisiana State University-Alexandria, USA

Noel L. Gauran, PhD
Statistics
Western Philippines University

Sujan M. Henkanaththegedara, PhD
Conservation Ecology
Longwood University, Virginia,
USA

Romeo R. Lerom, PhD
Plant Genetic Resources/Botany
Western Philippines University

Rosario Rivera Rubite, PhD
Plant Systematics, Molecular Biology,
Begoniaceae
University of the Philippines

Sabine Schoppe, PhD
Aquatic/Wildlife Ecology
Katala Foundation Inc.,
Philippines

Jun Akamine, PhD
Ecological Anthropology & Anthropology
of Food
Hitotsubashi University, Tokyo, Japan

Hernando P. Bacosa, PhD
Environmental Science
Texas A&M University at Galveston, USA

Lota A. Creencia, PhD
Fisheries & Aquatic Sciences
Western Philippines University
Palawan, Philippines

Hendrik Freitag, PhD
Entomology
Ateneo de Manila University, Philippines

Daniel J. Gurdak, MSc
Ecology & Conservation Biology
State University of New York, USA

Ravindra C. Joshi, PhD
Integrated Pest Management
Visiting Adjunct Professor of Agriculture
University of South Pacific, Suva, Fiji

Joie D. Matillano, MSc
Fish & Wildlife Biology & Management
Municipality of Taytay, Palawan, Phil.

V. Deepak Samuel, PhD
Marine Ecology
National Centre for Sustainable Coastal
Management, Chennai, India

Jonah van Beijnen, MSc
Sustainable Aquaculture/Conservation
Biology
Fins & Leaves, Europe

Editorial Staff

Rosalie S. Nostratis, PhD

Jireh J. Baltazar

Niño Jess Mar F. Mecha

Engr. Michael Angelo C. Maga-ao, MAM

Marites E. Lomocso, MLIS

Sarah Jane B. Torreflores

Jemima C. Daño

TECHNICAL ADVISERS

Elsa P. Manarpaac, PhD

*Developmental Communication
Western Philippines University*

Lawrence M. Liao, PhD

*Marine Plants
Hiroshima University, Japan*

Benjamin J. Gonzales, PhD

*Fish Biodiversity/Coastal Fisheries Mgt
Western Philippines University*

Nilo V. Banlawe, MSc

*Horticulture
Western Philippines University*

Julie Hope Timotea P. Evina, PhD

*Educational Management
Western Philippines University*

EDITORIAL

Becoming smarter and more innovative! This is one of the four areas of focus of the Philippine government over the next 25 years that will help realize its *Ambition Natin 2040*. Without research, we have nothing to innovate. A lot of innovation have grown out from research. As an intrinsic aspect of the development of idea, research helps turn that idea into an innovation. In the next few decades, innovation is predicted to originate from middle-income countries that puts premium on research and development. R&D is the backbone of a globally competitive and knowledge driven economy. R&D helps discover new materials and develop new products and services that create jobs and drive economic growth. The Philippines should join the bandwagon of nations with strong and robust R&D capacity in order to attain its Vision for 2040.

Moving towards this goal, the academia must also serve as incubators of idea and technology, and think-tank in the regions. But this can only be achieved if our universities are committed to high-impact research whose output is available to the public. The government's plan to bring development to the regions in order to decongest Metro Manila requires strong research-intensive universities in such areas. Among the typical examples is the Silicon Valley in the United States, an epicenter of world innovation, which has Stanford University and University of California-Berkeley; while Boston, another innovation hub, has MIT and Harvard. The Austin area in Texas is developing to be the next innovation center as well and that is tied to the presence of the University of Texas. Our universities in the Philippines must not get stacked in the old-fashioned style of educating the young people. We need an academic revolution to obliterate the traditional way of doing things. Our universities must strengthen research capabilities and undertake crucial roles in strengthening collaborations with the government, the industry and overseas institutions. With this in mind, it is not impossible to see the Silicon Valley of the Philippines that is fearless of failures, a beacon of knowledge and creativity, a haven of innovation, and a driver of entrepreneurial spirit.

In Palawan, the nature-rich and biggest province of the Philippines, The Palawan Scientist is trying to address this gap by providing a platform to make research work available to the scientific

community, and encouraging quality research. From its humble beginnings few years ago, the Journal is now indexed in Clarivate Analytics. In the current issue we have seven Original Research Articles, a Note, and a Review Paper for the first time. The review by Caipang and Avillanosa provides a comprehensive overview on the mechanism and application of biofloc technology (BFT) in freshwater tilapia farming. They highlighted that the complex physical, chemical, and biological interactions in the biofloc system require further studies. Multidisciplinary studies and international collaboration are necessary in order to unravel the complex processes and fine-tune this site-specific technology before the wider applications in sustainable aquaculture in developing countries such as the Philippines.

The goal of the Journal for 2019 is to increase paper citations and impact by soliciting more articles with high quality. I encourage researchers overseas especially those of Filipino descent and those with connection to the Philippines to contribute articles. As a third world country, researchers in the Philippines can boost further the quality of research by forging partnerships with developed countries who have always open doors for collaborative work. We just need to find the right place to go and the right person to connect us. I am looking forward to continue working with the Editorial Board and make The Palawan Scientist become a high-quality and high-impact scientific journal.

Hernando P. Bacosa
Texas A&M University at Galveston
Texas, USA

Backyard farming of tilapia using a biofloc-based culture system

Christopher Marlowe A. Caipang^{1,2} and Arlene L. Avillanosa³

¹DOST-Balik Scientist, Western Philippines University-
Puerto Princesa Campus, Palawan, Philippines

²Present Address: University of San Agustin,
General Luna St., Iloilo City 5000, Philippines

³College of Fisheries and Aquatic Sciences,
Western Philippines University-Puerto Princesa Campus,
Palawan, Philippines

Correspondence: cmacaipang@yahoo.com
<https://doi.org/10.69721/TPS.J.2019.11.1.01>

ABSTRACT

The pressures brought about by the increase in human population resulted in the rapid expansion of the food production industries including aquaculture to provide the nutritional requirements of the growing population. As aquaculture operations intensify, there is also an urgent need to preserve the environment; hence, all activities must be carried out in a sustainable way. The use of the biofloc technology (BFT) in aquaculture addresses these issues on restrictions on the usage of water and land as well as matters concerning sustainability of the production. BFT is a technique that maintains optimum water quality in the aquaculture system by manipulating the carbon and nitrogen ratios in the system. This optimum ratio favors the growth of heterotrophic bacteria that contribute in maintaining good water quality and at the same time provide sources of natural food for the cultured fish or crustaceans. In this review, the mechanisms of the biofloc technology particularly in the production of tilapia in freshwater systems are discussed. Moreover, some of the intrinsic advantages of this technology are highlighted in the context of developing and supporting backyard aquaculture of freshwater tilapias as a means of providing the food demands of the population in rural communities and as source of income for the marginalized small-scale fish farmers.

Keywords: BFT, fish farming, small-scale aquaculture, sustainable technology

INTRODUCTION

Global population is expected to reach 9.6 billion people by 2050 and it is important that the food demands of the growing population are met while safeguarding the world's natural resources for future generations (FAO 2014). In this regard, aquaculture has a crucial role in the elimination of hunger, promotion of good health, reduction of poverty and in the provision of jobs and economic opportunities. According to FAO (2014), fish production from

aquaculture is expanding at an annual rate of at least 6%. This sector provides jobs and supports livelihood of the population and proof of that is the fact that fish continues to be one of the most traded food commodities worldwide. In some cases, there are developing countries where fish and aquatic products would constitute half the total value of their traded commodities (Emerenciano et al. 2013).

Due to the rapid expansion of aquaculture, several technologies have been developed to ensure increased and sustainable production of fish and crustaceans. An example of such technology is biofloc technology or commonly known as BFT. This technology is an aquaculture practice that is based on natural processes that are widely occurring in the aquatic ecosystem. According to Emerenciano et al. (2013), BFT is considered as the new “blue revolution” because nutrients are continuously recycled and reused during the culture phase and at the same time there is minimum or zero-water exchange. The sustainable approach of this system is based on the high production of fish or shrimp in small areas but with minimal or zero discharge of wastewater back to the source, thereby reducing the ecological footprint. In addition, the bioflocs which are the products of this aquaculture technology are rich in proteins and lipids that could serve as natural sources of food for the cultured stock. These food resources are available in the culture system all day long as a result of the complex interaction between organic matter, the physical substrate and wide array of microorganisms (Emerenciano et al. 2013). The natural productivity in a biofloc-based aquaculture system enables the recycling of nutrients and maintaining the water quality in the pond or tank. The consumption of biofloc by shrimp or fish has resulted in a wide range of benefits including improvement of growth, decrease in feed conversion ratio (FCR) and associated costs in feed (Avnimelech 2015; Choo and Caipang 2015). In this type of aquaculture system, the growth of heterotrophic bacteria that assimilate the toxic ammonia-N from the water, and the corresponding increase in bacterial biomass is facilitated through supplementation of external organic carbon sources (Azim and Little 2008). This microbial biomass may further form aggregates with other micro- and macro-organisms including phytoplankton and zooplankton; hence the term “bioflocs” (Hari et al. 2004). Bioflocs are a rich source of growth promoters and bioactive composites, which enhance both the digestive enzymes and the health status of the aquatic organism (Hari et al. 2004; Choo and Caipang 2015).

This review discusses the mechanisms of the biofloc technology particularly in the production of tilapia in freshwater systems. Moreover, some of the intrinsic advantages of this technology are elucidated in the context of developing and supporting backyard aquaculture of freshwater tilapias as a means of answering the food demands of the population in rural

communities as well as a source of livelihood for the marginalized small-scale fish farmers.

THE BIOFLOC-BASED CULTURE SYSTEM

The biofloc technology as a type of an aquaculture system was believed to have started in the early 70s in France by IFREMER-COP (French Research Institute for Exploitation of the Sea - Oceanic Centre of Pacific) using shrimp as the main species for culture, with the concept being likened to an external rumen (Cuzon et al. 2004; Emerenciano et al. 2012b). In 1980, the Ecotron Science Program was started by IFREMER to better understand how such systems work through intensive research (Emerenciano et al. 2013). Later, research initiatives on BFT began in the USA and Israel in the late 80s and early 90s, respectively. The main focus of those activities was to develop an aquaculture technology using tilapia as a model culture species with the driving force of limiting water and land usage, as well as to finding ways of reducing the negative environmental impacts of the prevailing aquaculture practices (Emerenciano et al. 2013; Hargreaves 2013). The first commercial application of the biofloc concept took place at the Sopomer farm in Tahiti and at the Belize Aquaculture farms in 1988, where shrimp were reared in biofloc systems (Emerenciano et al. 2013). Today, BFT systems are being commercialized on a global scale, with tilapia and shrimp as the major species being used (Avnimelech 2015).

There are a few types of biofloc systems that are being used in both commercial aquaculture and in research. The two basic types of biofloc systems are those that are exposed to natural light and those that are not (Hargreaves 2013). Biofloc culture systems that are exposed to natural light include outdoor, lined ponds or tanks that are used for the culture of shrimp or tilapia. In this system, a complex mixture of algal and bacterial processes helps to control the water quality; hence, these are also known as the "greenwater" biofloc due to the greenish coloration of the water as a result of the dominance of the algal community. However, there are some biofloc systems that are not exposed to natural light, but are situated indoors with no exposure to natural light. This type of system operates as a "brown-water" biofloc, where only bacterial processes predominantly control the water quality (Pérez-Rostro et al. 2014; Hargreaves 2013)

The biofloc-based culture system is based on the principle of assimilating the dissolved ammonia-nitrogen (TAN) that is excreted by fish as metabolic waste and also through the breakdown of organic nitrogen such as uneaten fish feeds by heterotrophic bacteria and converting them into microbial protein (Avnimelech 1999; Hargreaves 2006; Crab et al. 2012). Figure 1 shows the general mechanisms of a biofloc-based culture system that is commonly used in the farming of fish and crustaceans. The excretion of

nitrogenous metabolic wastes and their subsequent assimilation by heterotrophic bacteria create a balance through the manipulation of the carbon-to-nitrogen ratio (C:N ratio) by adding various organic carbon sources to the water. The production of the heterotrophic bacterial biomass further results in the formation of macro-aggregates known as bioflocs. These bioflocs are composed of not only the bacteria but also other microorganisms including microalgae, zooplankton and trapped organic and inorganic particles (Hargreaves 2013). This concept is based on the production of predominantly heterotrophic bacteria, which can be attained by increasing the carbon to nitrogen ratio (C:N) within the water of the culture environment through the addition of organic carbon sources (Avnimelech 2015). In a biofloc-based culture system, the water is well-aerated and vigorously mixed

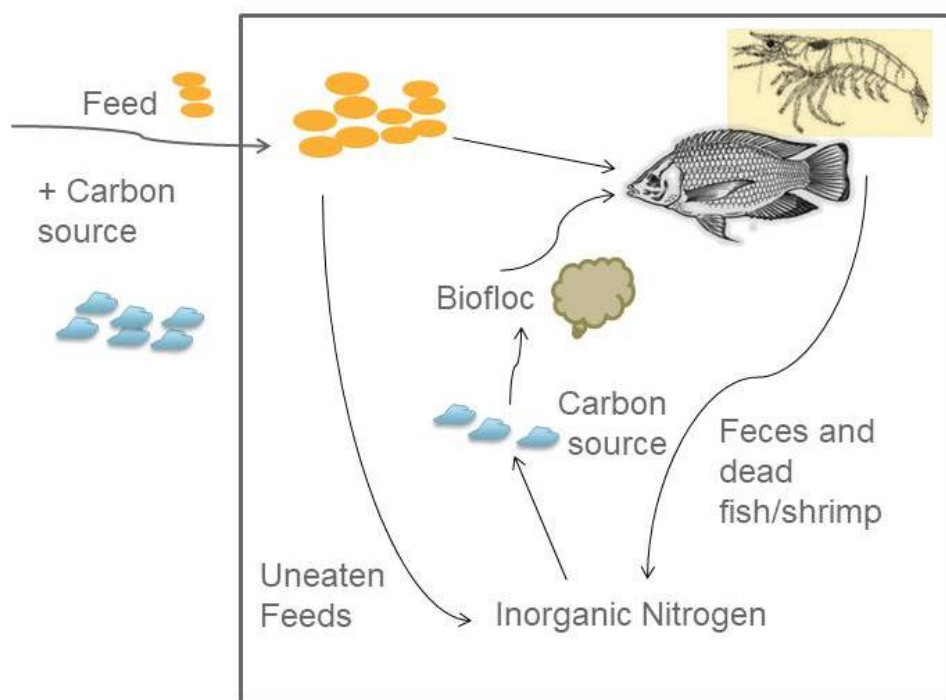

Figure 1. Mechanisms of the production and maintenance of bioflocs in ponds and tanks. Adapted from Crab et al. (2012)

to ensure that the heterotrophic bacteria remain in suspension and proliferate, and will have continuous supply of the nitrogenous compounds from fish wastes and excess feeds. The amount of nitrogen is the limiting factor to the growth of the heterotrophic bacterial community (Hargreaves 2013; Avnimelech 2015); hence, sufficient aeration and mixing are required to keep the flocs in suspension within the water column, thereby keeping the water quality controlled (Hargreaves 2013). The mixing has a critical role in keeping

the bioflocs in suspension, which also prevents anoxic conditions from developing at the bottom of the ponds or tanks (Avnimelech 2015). Table 1 shows some of the critical parameters that must be met and how these parameters are manipulated to ensure successful production of bioflocs in the rearing environment. By successfully implementing a BFT system in the farming of fish and crustaceans, the benefits can be attained in the following ways: firstly, toxic nitrogen species (especially the un-ionized ammonia) are eliminated from the water *in situ*, thus avoiding the need for expensive filtration systems, and at the same time allowing for higher stocking densities than that being practiced in extensive systems (Hargreaves 2013). Secondly, nutrients are recycled from the waste and converted into microbial protein by the bioflocs, which are then utilized by some filter-feeding aquatic organisms including tilapia and shrimp; hence, it significantly reduces the need for the provision of formulated feeds without adversely affecting the growth rate of the cultured stock (Avnimelech 2015). It should be noted that the optimum stocking densities for semi- or intensive systems that are being used for the culture of either tilapia or shrimp will likely be similar to those systems that will employ biofloc technology. The added benefits of using BFT in the culture system are discussed in the succeeding section of this review.

Table 1. Water parameters in a biofloc-based culture system and strategies in optimizing their effects on the production and maintenance of biofloc.

Water Quality Parameter	Floc Parameter/s Being Affected	Manipulation Strategies	Impact on other Water Quality Parameter
Water mixing/aeration	Floc structure and size	Choice of power input and type of aeration device	Dissolved oxygen
Organic carbon source	Chemical floc composition	Type of organic carbon source	Organic loading rate; Dissolved oxygen
Loading rate of organic matter	Microbial floc composition; chemical floc composition	Feeding strategy	Dissolved oxygen
Dissolved oxygen (DO)	Microbial floc composition; floc structure and volume	Choice of power input; Aeration device	Mixing intensity; Source of organic carbon
Temperature	Floc structure and activity	Addition of heat	Dissolved oxygen
pH	Floc stability	Addition of acid/base	Alkalinity; Conductivity

The data provided were adapted from Rathore et al. (2016).

The microbial community which is composed predominantly of heterotrophic bacteria in the water acts as a biofilter. Their presence results in a faster rate of increase in nitrogen uptake and reduced ammonia levels in comparison with the natural nitrification process (Avnimelech 1999; Crab et al. 2012). Biofloc systems have very low water exchange, and thus have a significantly lower impact on the surrounding environment through lesser water requirements and minimal or zero discharges of effluents (Avnimelech 2007 2012; Hargreaves 2013). Degradation of the environment is further reduced by the lower amount of pelleted feeds that are given to the cultured stock and the higher efficiency in recycling nutrients from the fish waste and uneaten feeds (Hargreaves 2013). With all these benefits, it is not surprising that large scale BFT systems have been set up in various parts of the world, with the smaller scale greenhouse biofloc systems having a wider application (Emerenciano et al. 2013).

The carbon to nitrogen ratio (C:N) has an integral part in the BFT system (Hargreaves 2013). It is through this ratio that effectively regulates the proliferation of heterotrophic bacteria, which are generally limited by the availability of organic carbon (Avnimelech 1999; Michaud et al. 2006; Emerenciano et al. 2013; Hargreaves 2013; Luo et al. 2014). By increasing the C:N ratio, the growth and production of heterotrophic bacteria is enhanced, and ammonia is taken up from the water and converted into microbial biomass that is rich in protein (Hargreaves 2013). The critical point of this ratio where heterotrophic bacteria will dominate nitrifying bacteria is variable depending on the type and quality of the organic carbon sources that are being used in the production of bioflocs (Michaud et al. 2006). For example, Luo et al. (2014) recommended that in a BFT system the C:N ratio should be maintained at greater than 10:1, while Hargreaves (2013) suggested that it should be closer to 12-15:1 to support the heterotrophic pathway. On the other hand, Emerenciano et al. (2013) pointed out that the optimal ratio of C:N is at the range of 15-20:1. From these studies, it is evident that there is no fixed C:N ratio, but all biofloc researchers are in agreement that the C:N ratio must be sufficiently elevated and this can be achieved through the provision of an additional organic carbon source to the water of the rearing environment.

In practice, the choice of an organic carbon source is largely dependent on the availability of a cheap carbon source that is near to where the BFT system is located (Emerenciano et al. 2013). A range of organic carbon sources such as wheat bran (Emerenciano et al. 2011; Emerenciano et al. 2012a), molasses (Burford et al. 2004;), glucose (Crab et al. 2010), cellulose (Avnimelech et al. 1989), cassava meal (Avnimelech and Mokady 1988; Chen et al. 2015), sorghum meal (Avnimelech et al. 1989; López-Elías et al. 2015), sweet potato flour (Caipang et al. 2015), wheat flour (Azim and Little 2008; Xu et al. 2012) and corn/maize meal (Milstein et al. 2001; Asaduzzaman et al. 2010; Xu et al. 2012) has been tested and proven to be

effective in producing and maintaining biofloc volume and density in the culture system. Table 2 shows some of the carbon sources that were tested for the maintenance of biofloc in selected aquaculture species. Wheat flour, starch, corn starch and cellulose were commonly used in tilapia culture, while wheat bran, molasses and glycerol were the common carbon sources in shrimp biofloc systems. The organic carbon source is linked to the feeding rate and is usually added to the water once, or twice a day and usually after feeding has taken place (Avnimelech 1999; Azim and Little 2008; Xu et al. 2012). The practical application and the specific routine when to add the organic carbon source is dependent on the nature of the BFT system that is being implemented (Avnimelech 1999). Before stocking of fish or crustaceans, biofloc-based culture units are thoroughly prepared for a number of weeks, where the water is seeded with biofloc water from an existing BFT pond or tank followed by fertilization with the organic carbon source and allowing the bioflocs to be produced and stabilized in the water column (Avnimelech 2012; Hargreaves 2013). Ekasari et al. (2014) recommended a three-week period of preparation until the total suspended solids (TSS) will exceed a concentration of 500 mg/L. Once this concentration is reached, stocking of fish or shrimp juveniles will commence. This recommended time frame is also in agreement with the suggestion of Avnimelech (2012). It should be noted that the water quality parameters fluctuate throughout this period of biofloc establishment and the various water quality parameters must be strictly monitored to ensure that these levels are within the optimum range for the rearing of either fish or crustaceans.

Table 2. Sources of organic carbon that are used for the production and maintenance of bioflocs in tilapia and shrimp culture.

Source of organic carbon	Cultured species
Acetate	<i>Macrobrachium rosenbergii</i>
Cassava meal	<i>Penaeus monodon</i>
Cassava flour	<i>M. rosenbergii</i> ; <i>Litopenaeus vannamei</i> ; <i>Oreochromis</i> sp.
Cellulose	<i>Oreochromis</i> sp.
Corn flour	<i>Oreochromis</i> sp.
Dextrose	<i>L. vannamei</i>
Glucose	<i>M. rosenbergii</i>
Glycerol	<i>M. rosenbergii</i>
Molasses	<i>L. vannamei</i> ; <i>P. monodon</i>
Sorghum meal	<i>Oreochromis</i> sp.
Starch	<i>Oreochromis</i> sp. and their hybrids
Wheat flour	<i>Oreochromis niloticus</i>
Wheat bran and molasses	<i>Farfantepenaeus brasiliensis</i> ; <i>Farfantepenaeus paulensis</i>

The data were modified from Caipang et al. (2015) and Rathore et al. (2016).

Most BFT systems are often situated in areas where there is scarcity of water supply. Limitations in the availability of water together with biosecurity issues in the aquaculture site have driven fish farmers to use the minimal to zero water exchange approach (Hargreaves 2013). The stability of zero or minimal water exchange depends on the dynamic interaction among communities of bacteria and other biotic communities that occur within the biofloc system. These aggregates of the microorganism help in the maintenance of the water quality and in the recycling of wastes to produce nutritious food for the cultured stock (Emerenciano et al. 2013). BFT is therefore perceived to be an environment-friendly aquaculture technique, with sustainability as the major issue it addresses (Widanarni et al. 2012).

ADVANTAGES OF BIOFLOC SYSTEM IN BACKYARD PRODUCTION OF TILAPIA

There are several factors that promote the implementation of the biofloc technique in aquaculture (Crab et al. 2012). Firstly, water has become scarce or expensive that it has become a limiting factor in aquaculture development. Secondly, the release of waste waters from the aquaculture sites into the environment is prohibited in some countries. Thirdly, severe outbreaks of infectious diseases resulted in the development of stringent biosecurity measures including the reduction of water exchange rates (Avnimelech 2015). Rathore et al. (2016) cited the many advantages of a biofloc-based system in the rearing of fish and crustaceans. These include its applications in the breeding, nursery and grow-out production of both shrimp and some species of fish as well as it can be integrated into the aquaponics system of fish and vegetable production. Because bioflocs harbor a number of microorganisms, it can also act as natural probiotics in the system (Avnimelech 1999).

The species that are chosen to be cultured in a BFT system must be able to tolerate sub-optimal water quality with high suspended solids, and must have the ability to obtain nutrition from the bioflocs through filter feeding (Crab et al. 2012; Hargreaves 2013). Furthermore, it is suggested by Crab et al. (2012) that the focus on the choice of the aquaculture species should be on the lower trophic species, which exhibit an herbivorous diet. Hargreaves (2013) indicated that shrimp, carp and tilapia meet these requirements and as a result they are being used as the species of choice in almost all BFT systems worldwide. To a certain extent, some studies have also shown the potential of using sturgeon and some species of catfish (Serfling 2006; Green et al. 2014).

Tilapia has been deemed as the fish of the 21st century (El-Sayed 2013), with a continued rise in its share of global fish production. Currently it

is the most widely produced species around the world, with production being recorded in 135 countries (FAO 2014). The production systems for tilapia culture are usually simple extensive or modified semi-intensive systems, with only the basic techniques required for successful cultivation. This species of fish favors warmer water and because it can be easily cultured (El-Sayed 2013), tilapia shows great aquaculture potential in many developing countries that are located in warmer regions. The hardy nature of the species is evident in the wide range of environmental parameters that can be tolerated by tilapia (Boyd 2004; Jamandre et al. 2011). This trait is beneficial during the culture phase, where there may be a lack in the availability of effective mechanisms for water quality control and monitoring due to the nature of the prevailing systems. Even though tilapias are being positioned at a low-trophic level with its omnivorous feeding habits (Njiru et al. 2004; Fitzsimmons et al. 2011), they are able to effectively utilize a plant-based diet and the corresponding product at harvest is well accepted by the consumers (Andretto et al. 2015). The role of freshwater fish farming, identified as the major mechanism towards attaining food and protein security (FAO 2014), cements the place of tilapia in the future as a key aquaculture species in most developing countries. With large portions of the population in developing countries living below the poverty line, the potential for tilapia culture employing the basic culture methods is recommended.

Tilapia farming in biofloc systems is very promising because it uses minimal or zero water exchange, can be stocked at high densities, can reach high yields due to the availability of natural food by manipulating the C:N ratio in the water and better water quality because of the presence of microorganisms that remove and recycle nutrients (De Schryver et al. 2008; Crab et al. 2012; Emerenciano et al. 2013; Avnimelech 2012). Also, the physiological functions such as immune and antioxidant systems, which are essential for tilapias in maintaining their health and growth performance (Shourbela et al. 2017) are also enhanced in biofloc-based culture systems. The presence of bioflocs is also shown to enhance immune functions of the fish (Azim and Little 2008). An improved immunity in fish and better antioxidant defense mechanism would likely result in higher resistance against pathogens that will prevent disease outbreaks (Bachère 2000).

In addition to maintaining optimum water quality in tilapia ponds and tanks via the uptake of nitrogenous compounds to generate microbial proteins on-site, biofloc-based culture system also increases fish production by reducing feed conversion ratio through higher protein utilization and lower inputs of commercial feed, thereby decreasing feed cost (Choo and Caipang 2015). The cost of feeds represents at least 50% of the total aquaculture production cost, which is predominantly due to the high cost of the protein component in commercial diets (De Schryver et al. 2008). Tilapia ingest a wide variety of natural food organisms including plankters, aquatic

macrophytes, planktonic and benthic aquatic invertebrates, detritus and decomposing organic matter. With heavy supplemental feeding, natural food organisms typically account for 30 - 50% of tilapia growth (Emerenciano et al. 2013). The gills of tilapia secrete mucus that traps planktonic organisms. The plankton-rich mucus is then swallowed and is a rich source of nutrients for the fish. In general, tilapia uses natural food efficiently and their production can be sustained in well-fertilized ponds even without the addition of supplemental feeds (Popma and Lovshin 1996). As such, in a biofloc-based culture system, tilapias are able to efficiently utilize single-cell microbial proteins that are produced by the heterotrophic bacteria through assimilation of inorganic nitrogen (TAN) from the water. These characteristics of tilapia favor them to be suitable fish species that can be cultured using bioflocs.

So how will a biofloc-based culture system of tilapia contribute towards the successful implementation of backyard aquaculture? It is widely known that marginalized fish farmers would greatly benefit from using this simple aquaculture technology. The small-scale or marginalized fish farmers in developing countries are often poorer than the rest of the population and they have less access to proper nutrition in order to lead healthy lives (Matte 2019). As such, alleviating poverty and hunger means confronting the problems that farmers face in their daily struggle for survival. Through backyard farming of tilapia using low inputs, which are the beneficial features of a biofloc-based culture system, it contributes immensely to the food needs as well economic empowerment of many families especially in rural communities. The fish farmers are able to be productive all-year round; thus, fully maximizing fish production (Mathias 1998), as tilapias are tolerant to wide fluctuations in environmental conditions. In addition, the requirements for the establishment of a biofloc system for backyard aquaculture of freshwater tilapia are cheap and readily available as materials. The rearing units can be sourced from scrap such as used canvass tanks and the food to be given to the fish could include food and vegetable wastes. The carbon sources for the production and maintenance of biofloc are all by-products of the food production process, which may include molasses and fermented vegetables. All the inputs in a biofloc-based culture system can be easily procured by small-scale fish farmers to start their aquaculture activity regardless of their location. The main problem that these small-scale fish farmers would likely encounter is how to maintain constant aeration in the biofloc tanks to ensure that the biofloc particles are kept in suspension. This can be addressed by stocking the fish at low densities so that there will be no problems with oxygen depletion. To provide aeration to the tank, the fish farmers can fabricate aeration systems from scrap materials and these will only be run at short durations during the day so as to save on electricity or fuel costs. These advantages of a biofloc-based culture system for freshwater tilapia would definitely be attractive to small-scale fish farmers to start

farming of fish in their backyards as their source of food and at the same time as potential source of livelihood.

FUTURE PERSPECTIVES AND CONCLUSION

Biofloc-based culture system for tilapia has an immense potential in addressing issues on income instability, food insecurity, unemployment and poverty of small-scale farmers in most rural communities. As biofloc technology can only be applied predominantly in land-based aquaculture, fish farmers should rethink of a paradigm shift towards setting up more land-based rural aquaculture using biofloc technology as a substitute for intensive fish cage farming where fish kills are becoming more frequent. A variety of beneficial features can be attributed to biofloc technology. These advantages range from water quality control to source of feed and even in the inhibition of certain pathogens. Biofloc technology will enable aquaculture to shift towards an environment-friendly approach and biosecure culture operations. The consumption of microorganisms by the cultured stock in a biofloc-based culture system will significantly reduce feed conversion ratio (FCR) and consequently the costs in feed. Also, microbial community is able to rapidly convert toxic nitrogenous wastes that are derived from the feces of fish or shrimp and uneaten feeds and subsequently convert them into microbial protein. The conversion of toxic nitrogenous wastes to the less toxic forms is crucial in maintaining optimum water quality in biofloc-based culture systems. It would be an interesting topic for future research to determine the composition of bacterial population in a biofloc system so as identify and isolate beneficial heterotrophic bacterial species that are responsible for the added benefits of bioflocs in aquaculture.

The physical, chemical, and biological interactions that occur within the biofloc systems are complex; hence, further studies are needed to elucidate specific phenomena and their possible applications to other fields, and such interactions that take place in freshwater tilapia culture system should not be overlooked as well. Given the numerous benefits of bioflocs to tilapia aquaculture, BFT also provides a sustainable way to simultaneously address the environmental, social and economic issues that are related to the growth of this particular aquaculture sector. As an ecologically-friendly culture system that is characterized by reduced wastes, the ecological importance of the biofloc-based culture system must be taken seriously into consideration as this will impact its sustainability. In this regard, clear linkages between aquaculture and the environment must be defined and made known to all stakeholders. In addition, it is a challenge to the tilapia researchers and farmers to collaborate in order to further develop and refine BFT as the requirements could be site-specific. The basic principles of the

BFT are already available, but further development of this technology needs fine-tuning and its implementation needs further research to enable this technique become a major feature of sustainable aquaculture in the future.

ACKNOWLEDGEMENTS

The preparation of this review paper was partly supported by the WPU Extension Program, “Western Philippines University Learning Environment-friendly Advocacy Farm and Family-based Education Towards Fisheries Resource Management and Popularization of Aquaculture and Alternative Agriculture in Western Philippines” funded by CHED-NAFES Extension Project. CMA Caipang is supported by the Balik Scientist Program of the Department of Science and Technology, Philippines through the Philippine Council for Agriculture, Aquatic and Natural Resources Research and Development (PCAARRD). Logistics provided by the College of Fisheries and Aquatic Sciences, Western Philippines University, Puerto Princesa is also gratefully acknowledged. The comments and suggestions made by the two anonymous reviewers for the improvement of the manuscripts are greatly appreciated.

REFERENCES

- Andretto AP, Lösch JA, Goncalves GA, Fuzinatto MM, de Lima DP, Braccini GL, Filho LA, Canan C, Peralta RM and Vargas L. 2014. Assessment of the oxidative state, related parameters and quality of muscle tissue in Nile tilapia with the application of homeopathic product Homeopatila 100® in high-density cages. *African Journal of Pharmacy and Pharmacology*, 9: 279–286.
- Asaduzzaman M, Rahman MM, Azim ME, Ashraful Islam M, Wahab MA, Verdegem MCJ and Verreth JAJ. 2010. Effects of C/N ratio and substrate addition on natural food communities in freshwater prawn monoculture ponds. *Aquaculture*, 306: 127–136.
- Avnimelech Y. 1999. Carbon and nitrogen ratio as a control element in aquaculture systems. *Aquaculture*, 176: 227–235.
- Avnimelech Y. 2007. Feeding with microbial flocs by tilapia in minimal discharge bioflocs technology ponds. *Aquaculture*, 264: 140–147.
- Avnimelech Y. 2015. *Biofloc Technology – A Practical Guide Book*. 3rd ed. The World Aquaculture Society, Baton Rouge, Louisiana, United States. 258 pp.
- Avnimelech Y and Mokady S. 1988. Protein Biosynthesis in Circulated Fishponds. In: Pullin RSV, Bhukaswan T, Tonguthai K and Maclean JL (eds). *ICLARM, 2nd International Symposium on Tilapia in*

- Aquaculture, Bangkok, 16-20 March 1987. ICLARM, Manila, Philippines, pp. 301-309.
- Avnimelech Y, Mokady S and Schroeder GL. 1989. Circulated ponds as efficient bioreactors for single cell protein production. *The Israeli Journal of Aquaculture*, 41: 58-66.
- Azim ME and Little DC. 2008. The biofloc technology (BFT) in indoor tanks: water quality, biofloc composition, and growth and welfare of Nile tilapia (*Oreochromis niloticus*). *Aquaculture*, 283: 29-35.
- Bachère E. 2000. Introduction: shrimp immunity and disease control. *Aquaculture*, 191: 3-11.
- Boyd C. 2004. Farm-level issues in aquaculture certification: Tilapia, Report commissioned by WWF-US. Auburn University, Alabama, USA. 29 pp.
- Burford MA, Thompson PJ, McIntosh RP, Bauman RH and Pearson DC. 2004. The contribution of flocculated material to shrimp (*Litopenaeus vannamei*) nutrition in a high-intensity, zero exchange system. *Aquaculture*, 232: 525-537.
- Caipang CMA, Choo HX, Bai Z, Huang H and Lay-yag CM. 2015. Viability of sweet potato flour as carbon source for the production of biofloc in freshwater culture of tilapia, *Oreochromis* sp. *International Aquatic Research*, 7: 329-336. DOI: 10.1007/s40071-015-0117-7.
- Chen QL, Zhang RJ, Wang YH, Zhao YZ, Chen JH, Zhang HH, Tian XY and Qin LY. 2015. The effect of biofloc technology on nursery system of *Litopenaeus vannamei*. *Applied Mechanics and Materials*, 737: 358-361.
- Choo HX and Caipang CMA. 2015. Biofloc technology (BFT) and its application towards improved production in freshwater tilapia culture. *AAFL Bioflux*, 8: 362-366.
- Crab R, Chielens B, Wille M, Bossier P and Verstraete W. 2010. The effect of different carbon sources on the nutritional value of bioflocs, a feed for *Macrobrachium rosenbergii* postlarvae. *Aquaculture Research*, 41: 559-567.
- Crab R, Defoirdt T, Bossier P and Verstraete W. 2012. Biofloc technology in aquaculture: beneficial effects and future challenges. *Aquaculture*, 356-357: 351-356.
- Cuzon G, Lawrence A, Gaxiola G, Rosas C and Guillaume J. 2004. Nutrition of *Litopenaeus vannamei* reared in tanks or in ponds. *Aquaculture*, 235: 513-551.
- De Schryver P, Crab R, Defoirdt T, Boon N and Verstraete W. 2008. The basics of bioflocs technology: the added value for aquaculture. *Aquaculture*, 277: 125-137.
- Ekasari J, Azhar M, Surawidjaja E and Nuryati S. 2014. Immune response and disease resistance of shrimp fed biofloc grown on different carbon sources. *Fish & Shellfish Immunology*, 41: 332-339.
- El-Sayed AFM. 2013. An overview of aquaculture in Egypt with focus on tilapia culture. Presented at the 11th conference of the aquaculture

- association of Southern Africa, Stellenbosch University, Stellenbosch, 9-13 September 2013.
- Emerenciano M, Ballester El, Cavalli RO and Wasielesky W. 2011. Effect of biofloc technology (BFT) on the early post larval stage of pink shrimp *Farfantepenaeus paulensis*: growth performance, floc composition and salinity stress tolerance. *Aquaculture International*, 19: 891-901.
- Emerenciano M, Cuzon G, Goguenheim J, Gaxiola G and AQUACOP. 2012a. Floc contribution on spawning performance of blue shrimp *Litopenaeus stylirostris*. *Aquaculture Research*, 44: 75–85.
- Emerenciano M, Ballester ELC, Cavalli RO and Wasielesky W. 2012b. Biofloc technology application as a food source in a limited water exchange nursery system for pink shrimp *Farfantepenaeus brasiliensis* (Latreille, 1817). *Aquaculture Research*, 43: 447-457.
- Emerenciano M, Gaxiola G and Cuzon G. 2013. Biofloc Technology (BFT): A Review for Aquaculture Application and Animal Food Industry. In: Matovic MD (ed). *Biomass now – Cultivation and Utilization*. InTech, Queen’s University, Belfast, Canada, pp. 301–328.
- FAO (Food and Agriculture Organization). 2014. *The State of World Fisheries and Aquaculture 2014. Opportunities and Challenges*. FAO, Rome, Italy. 223pp.
- Fitzsimmons K, Martinez-Garcia R and Gonzalez-Alanis P. 2011. Why tilapia is becoming the most important food fish on the planet. In: Liping L and Fitzsimmons K (eds). *Better Science, Better Fish, Better Life*. 9th International Symposium on Tilapia in Aquaculture, Shanghai, 22-24 April 2011, pp. 9-18.
- Green BW, Schrader KK and Perschbacher PW. 2014. Effect of stocking biomass on solids, phytoplankton communities, common off-flavors, and production parameters in a Channel Catfish biofloc technology production system. *Aquaculture Research*, 45: 1442–1458.
- Hargreaves JA. 2006. Photosynthetic suspended growth systems in aquaculture. *Aquacultural Engineering*, 34: 344-363.
- Hargreaves JA. 2013. *Biofloc production systems for aquaculture*. SRAC Publication number 4503. 12pp.
- Hari B, Kuru BM, Varghese JT, Schrama JW and Verdegem MCJ. 2004. Effects of carbohydrate addition on production in extensive shrimp culture systems. *Aquaculture*, 241: 179–194.
- Jamandre WE, Hatch U, Bolivar RB, Borski R. 2011. Improving the Supply Chain of Tilapia Industry in the Philippines. In: Liping L, Fitzsimmons K (eds). *Better Science, Better Fish, Better Life*. 9th international symposium on tilapia in aquaculture, Shanghai, 22-24 April 2011, pp. 153 – 174.
- López-Elías JA, Moreno-Arias A, Miranda-Baeza A, Martinez-Cordova LR, Rivas-Vega ME and Marquez-Rios E. 2015. Proximate composition of bioflocs in culture systems containing hybrid Red tilapia fed diets with

- varying levels of vegetable meal inclusion. *North American Journal of Aquaculture*, 77: 102–109.
- Luo GZ, Gao Q, Wang CH, Liu WC, Sun DC, Li L, Tan HX. 2014. Growth, digestive activity, welfare, and partial cost-effectiveness of genetically improved farmed tilapia (*Oreochromis niloticus*) cultured in a recirculating aquaculture system and an indoor biofloc system. *Aquaculture*, 422-423: 1-7.
- Mathias J. 1998. Integrated Fish Farming in the Context of World Food Security. In: Mathias JA, Charles AT and Hu B (eds). *Proceedings of a Workshop on Integrated Fish Farming held in Wuxi, Jiangsu Province, People's Republic of China. October 11-15, 1994*. CRC Press. Boca Raton, New York, pp. 3-18.
- Matte R. 2019. Analysis of the East African community integration process as an opportunity for Uganda's medium-to-long-term development. *Economics, Law and Policy*, 2: 12-54.
- Michaud L, Blancheton JP, Bruni V and Piedrahita R. 2006. Effect of particulate organic carbon on heterotrophic bacterial populations and nitrification efficiency in biological filters. *Aquaculture Engineering*, 34: 224–233.
- Milstein A, Avnimelech Y, Zoran M and Joseph D. 2001. Growth performance of hybrid bass and hybrid tilapia in conventional and active suspension intensive ponds. *Israeli Journal of Aquaculture – Bamidgeh*, 53: 147– 157.
- Njiru M, Okeyo-Owuor JB, Muchiri M and Cowx IG. 2004. Shifts in the food of Nile tilapia, *Oreochromis niloticus* (L.) in Lake Victoria, Kenya. *African Journal of Ecology*, 42: 163–170.
- Pérez-Rostro CI, Pérez-Fuentes JA and Hernández-Vergara MP. 2014. Biofloc, a Technical Alternative for Culturing Malaysian prawn, *Macrobrachium rosenbergii*. In: Hernandez-Vergara MP (ed). *Sustainable Aquaculture Techniques*. InTech. DOI: 10.5772/57501.
- Popma TJ and Lovshin LL. 1996. Worldwide Prospects for Commercial Production of Tilapia. In: *Research and Development Series 41*, International Centre for Aquaculture and Aquatic Environments, Auburn University, Alabama, pp. 1 – 42.
- Rathore SS, Yusufzai SI and Katira NN. 2016. Biofloc technology – the futuristic technology for improving the ecological and economic sustainability of aquaculture. *Life Sciences International Research Journal*, 3: 29-32.
- Serfling SA. 2006. Microbial flocs: natural treatment method supports freshwater, marine species in recirculating systems. *Global Aquaculture Advocate*, pp. 34–36.
- Shourbela RM, El-Kholya SZ and El-Fadadney M. 2017. Consequences of high-density fish culture as monitored by growth, behavior and immune responses of Nile tilapia (*Oreochromis niloticus*). *Alexandria Journal of Veterinary Sciences*, 53: 45-53.

- Widanarni W, Ekasari J and Maryam S. 2012. Evaluation of biofloc technology application on water quality and production performance of red tilapia *Oreochromis* sp. cultured at different stocking densities. *Hayati Journal of Biosciences*, 19: 73–80.
- Xu W-J, Pan L-Q, Zhao D-H and Huang J. 2012. Preliminary investigation into the contribution of bioflocs on protein nutrition of *Litopenaeus vannamei* fed with different dietary protein levels in zero-water exchange culture tanks. *Aquaculture*, 350– 353: 147–153.

ARTICLE INFO

Received: 07 February 2019

Revised: 26 June 2019

Accepted: 28 June 2019

Available online: 08 July 2019

Role of authors CMAC - conceptualized, wrote and revised the review paper; AL A - co-wrote, conducted literature search and proof-read the manuscript

Molecular characterization and tissue distribution of cysteamine dioxygenase (ADO) in common carp *Cyprinus carpio*

Maria Mojena Gonzales-Plasus^{1,2}, Yutaka Haga¹, Hidehiro Kondo¹, Ikuo Hirono¹ and Shuichi Satoh¹

¹ Department of Marine Biosciences,
Tokyo University of Marine Science and Technology,
Konan, Minato 4-5-7, Tokyo 108-8477, Japan.

²College of Fisheries and Aquatic Sciences,
Western Philippines University,
Puerto Princesa City, Palawan, Philippines

Correspondence: mojenagonzales@yahoo.com
<https://doi.org/10.69721/TPS.J.2019.11.1.02>

ABSTRACT

The low production of hypotaurine from cysteine but a significantly high taurine deposition in common carp led to the hypothesis that this species utilizes an alternative pathway other than the cysteine sulfinic acid pathway. Cysteamine pathway is common in mammals but not in other animals such as birds, invertebrates, and fishes. The cloned cysteamine dioxygenase (ADO) cDNA in common carp consists of 790 nucleotide bases with 260 deduced amino acid sequence. The conserved domain is the DUF1637 which has a conserved tyrosine and cysteine residues and the presence of three predicted N-glycosylation sites. Phylogenetic analysis using neighbor joint method indicated that ADO in common carp branched after *Sinocyclocheilus rhinoceros*. ADO was expressed in hepatopancreas, brain, gill, intestine, and muscle of common carp. The hepatopancreas had a significantly higher gene expression level than the other organs examined. The present results suggest that ADO is present in common carp.

Keywords: ADO, tissue distribution, cysteamine pathway

INTRODUCTION

There are three identified taurine synthesizing pathways namely cysteine sulfinic acid, cysteamine and cysteic acid pathways (Griffith 1987; Huxtable 1992; Stipanuk 2004) (Figure 1). Cysteine sulfinic acid pathway is present in teleost such as rainbow trout *Oncorhynchus mykiss* (Yokoyama and Nakazoe 1991). In this pathway, L-cysteine is oxidized by cysteine dioxygenase (CDO), which generates cysteine sulfinic acid that is decarboxylated by cysteine sulfinic acid decarboxylase (CSD) which converts cysteine sulfinic acid to hypotaurine (Griffith 1987; Yokoyama et al. 2001; Goto et al. 2001a; Higuchi et al. 2012). The cysteamine pathway, on the other hand, is said to be being utilized by chicken *Gallus gallus* (Kataoka et al. 1988). In this

pathway, the cysteine together with degraded co-enzyme A will form cysteamine which acts as a substrate for cysteamine dioxygenase (ADO), ADO will then convert cysteamine into hypotaurine, and further, oxidize hypotaurine to taurine (Stipanuk and Ueki 2011). Recently, the enzyme ADO was reported to be present in cobia *Rachycentron canadum* (Watson et al. 2015). The cysteic acid pathway which converts sulfate to cysteate and then to taurine by means of cysteic acid decarboxylase (CAD) is being utilized by microalgae and bacteria (Jacobsen and Smith 1968; Tevatia et al. 2015). The CSD is thought to be the rate limiting enzyme in taurine production, and its activity in freshwater fishes is higher than that of marine fishes (Goto et al. 2003). Most of the previous studies on taurine synthesis focused on cysteine sulfinic pathway and less on cysteamine pathway.

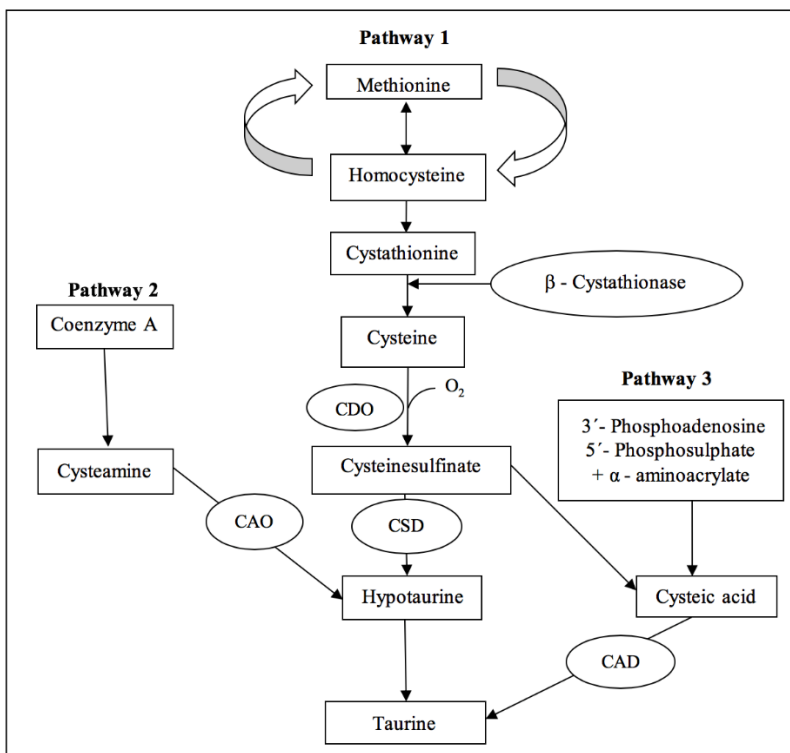

Figure 1. Metabolic pathways of Taurine modified from Griffith (1987).

Hepatic CSD expression was demonstrated in various teleosts such as common carp, Japanese flounder *Paralichthys olivaceus*, Japanese seabass *Lateolabrax japonicus*, rainbow trout *Oncorhynchus mykiss*, red sea bream *Pargus major*, yellowtail *Seriola quinqueradiata*, barfin flounder *Verasper*

moseri and zebrafish *Danio rerio* (Goto et al. 2001b; Chang et al. 2013; Haga et al. 2015; Wang et al. 2015; 2016). The fact that the high amount of taurine being deposited in common carp even if the CSD activity was low led to the possibility that common carp utilizes another pathway than cysteine sulfinic acid pathway for taurine production (Yokoyama et al. 2001).

Aside from production of taurine from cysteamine into hypotaurine and then taurine, cysteamine also plays a role in maintaining the level of cysteine to avoid cysteine toxicity. Both cysteine and cysteamine if present in high amount could be toxic to fish and affect the growth. The ADO is not yet molecularly characterized and its tissue distribution is still unknown. Hence the objective of this study is to clone and characterize ADO gene from juvenile common carp and analyze the tissue distribution and gene expression of ADO present in their organs.

METHODS

Fish

The five fish having an average initial weight of 3.85 ± 0.75 g were stocked in a 60 L glass tanks. Hand feeding was conducted twice a day until satiation. A recirculating system was utilized for the entire culture period with water temperature ranging from 23.5 ± 0.5 °C, and ammonia was monitored daily.

Juvenile common carp was euthanized with an overdose of 2-phenoxyethanol (Wako Pure Chemical Industries, Osaka, Japan) before dissection and collection of organs. Hepatopancreas, brain, gills, intestine, muscles, eye, heart, spleen, kidney and gallbladder were sampled from five fish and tissues were preserved using 1000 μ l RNA later (Ambion by life technologies, CA, USA) in an Eppendorf tube and kept at -80°C until analysis.

RNA extraction and cDNA cloning

Total RNA was isolated from the liver using TRIzol following the manufacturer's protocol. Digestion of total RNA followed thereafter using RNase-free DNase and cDNA was synthesized using the high capacity cDNA reverse transcription kit (Applied Biosystems, CA, USA).

The PCR product was ligated using pGEM T-Easy Vector and cloned using JM 109 competent cells (Promega Corp., Maddison, USA). The primer sequence for RACE PCR was determined according to the subcloned sequence and was amplified using Smart RACE Kit (Clontech Laboratories, Inc. Siga,

Japan). RACE PCR conditions for ADO were as follows: initial denaturation for five minutes at 95°C, 35 cycles of denaturation for 30 seconds at 95°C; annealing for 30 seconds at 68°C; extension for 1 min at 72°C, and final denaturation for five minutes at 72°C. PCR products were sequenced using the Big Dye Terminator Cycle Sequencing Kit version 3.1 (Applied Biosystems, Tokyo, Japan).

Phylogenetic analysis

Sequences used for phylogenetic analysis were obtained from the National Center for Biotechnology Information (NCBI). Alignment was done using ClustalW (Larkin et al. 2007). Validation of speciation occurred on ADO in teleost based on tree branching, an evolutionary distance of ADO genes from other teleosts by branch lengths and the clades classification and its bootstrap value were analyzed by constructing a Phylogenetic tree using neighbor joining method (Saitou and Nei 1987) with 1000 bootstrap value.

Domain analysis of deduced amino acid sequence from juvenile common carp for ADO gene was carried out using blast online software (Altschul, et al., 1990). A total of twelve species of fish were used for domain analysis (GeneBank accession number: *Sinocyclocheilus rhinoceros* (XP_016399656), *Danio rerio* (NP_998358), *Salmo salar* (XP_014060776), *Esox lucius* (XP_010868171), *Lepisosteus oculatus* (XP_006630446), *Pygocentrus nattereri* (XP_017549864), *Larimichthys crocea* (XP_010750130), *Xiphophorus maculatus* (XP_005806180), *Lates calcarifer* (XP_018516308), *Paralichthys olivaceus* (XP_019969282), *Ictalurus punctatus* (XP_017332680), *Oreochromis niloticus* (XP_005473824) and *Cyprinus carpio* (MK035000)).

Gene expression and tissue distribution analysis

The cDNA was synthesized using the high capacity cDNA reverse transcription kit (Applied Biosystems, CA, USA) and Thunderbird SYBR green Q-PCR mix (Toyobo Co., LTD Life Science Department, Osaka, Japan) was used for Q-PCR mix. Samples for Q-PCR were analyzed using the StepOne™ Real-Time PCR System (96 wells) (Thermo Fisher Scientific, Grand Island, USA) following the standard/default run mode. Beta-actin for common carp were used as an internal control and primers were designed against highly conserved region. All primers used for gene expression analysis and cloning were in Table 1. The condition of RT-PCR was as follows: initial denaturation for five minutes at 95°C, 35 cycles of denaturation for 30 sec at 95°C; annealing for 30 sec at 55°C; extension for 1 min at 72°C, and final denaturation for five min at 72°C. While for Q-PCR for stage 1 was 1 min at 95°C: followed by stage

2 for 40 cycles for 0.9 min at 95°C and 1 min at 60°C; and melt curve 15 sec at 95°C, 1 min at 60°C and 15 sec at 95°C.

Statistical analysis was performed using one-way ANOVA, normality test was performed using Bartlett's test and the difference among means was analyzed using Tukey's test ($P < 0.05$).

Table 1. Primers used in molecular characterization and gene expression analysis of ADO in Common carp *Cyprinus carpio*.

Primer	Primer Sequence
<i>RACE PCR Primers</i>	
ADO GSP 5'	ATGATGCCACGAGACAACATGACTTCCAC
ADO GSP 3'	ATCTTCAAGTCCGCCGCTCTG
<i>RT-PCR and Q-PCR Primers</i>	
β actin 5'	GGACTCTGGTGATGGTGTCA
β actin 3'	CTGTAGCCTCTCTCGGTCAG
ADO 5'	ATGATGCCACGAGACAACATGACTTCCAC
ADO 3'	ATCTTCAAGTCCGCCGCTCTG

RESULTS

Molecular characterization

Full length nucleotide sequences of ADO for common carp (MK035000) were 790 nucleotide bases with the deduced amino acid sequence of 260 amino acids (Figure 2). The conserved domain found in the sequence was the DUF1637, which has conserved tyrosine and cysteine residues. In addition, there was also a presence of three predicted N-glycosylation sites in ADO (Figure 2).

Alignment of deduced amino acid for ADO is shown in Figure 3, and the conserved region was almost similar in all teleost. The ADO of bird *Lonchura striata domestica* (XP_021391450.1) claded with that of mouse *Mus musculus* (AAH58407.1), human *Homo sapiens* (NP_116193.2), and cat *Felis catus* (XP_003994017.3) ADO sequence (Figure 3). The result of phylogenetic analysis with respective bootstrap value is shown in Figure 4. The ADO in teleost has two major clades one consist of four fish species belonging to family Ictaluridae, Salmonidae and Cyprinidae (*Ictalurus punctatus*

(XP_017332680.1) (82%), *Salmo salar* (NP_001134267.1) (62%), *Sinocyclocheilus rhinoceros* (XP_016399656.1) and *Cyprinus carpio* (MK035000) (100%) (Figure 4). While the other clade consists of five fish species belonging to Poeciliidae, Cichlidae, Sciaenidae, Paralichthyidae and Carangidae (*Poecilia reticulata* (XP_017166122.1) (68%), *Maylandia zebra* (XP_004570438.1) (68%), *Larimichthys crocea* (KKF18981.1) (74%), *Seriola dumerili* (XP_022621764.1)(82%), and *Paralichthys olivaceus* (XP_019939118.1)(83%)) (Figure 4). The ADO of common carp had 100% bootstrap value with *Sinocyclocheilus rhinoceros* (XP_016399656.1) (Figure 4).

```

attatgatgccacgagacaacatgacttcactgtccagaaaatgccagacaggccctc
I M M P R D N * M T S T V Q K I A R Q A L
acgacgttcagaaaccctcgcttgcggagaacactataaagtgttttgaaaacctg
T T F R N * P S L V G E H Y K V F L E N * L
agcaagctgaaaagccttatggcggagggtcaaagcggcggacttgaagatcgcaccccg
S K L K S L M A E V K A A D L K I A P R
agcaccgagagcgcgccggcgcttccgcgcgtcccggctcccgttacatacatgca
S T E S A P G P S P R V P A P V T Y M H
atctacgagaccgacagcttcagcatgggggggttttattaaaaggccgcttcgata
I Y E T D T F S M G G F L L K R A A S I
ccctccggttcatccgggaatgtacggcatgctgaaagtatttacggcaaggtgcga
P L P V H P G M Y G M L K V I Y G K V R
atcagctgtttgacatgttgataaacctcgagacggtgccagcggcgtgcagttcagc
I S C F D M L D K P R D G A S G V Q F S
cctccgctctacccttccggagcagctctcttccgccctcggggctgaggtcggggggg
P P L Y P F R S S S L P P S G L R S G G
gaatacacggagagagcggcccggtgtgtgtgtcaccctcaaaagaacaatatccaccag
E Y T E E S G P C V L S P Q K N N I H Q
atagacgctgttgacggaccacggcttcttctgacatcttaccgccgctatgatccg
I D A V D G P T A F L D I L S P P Y D P
gaagaaggagagactgccattataataaggttttgcattgccattcagaggctgcagac
E E G R D C H Y N K V L H A H S E A A D
agaagagtgaaagccaggaccgccgggtgacctgtggctcgtggagatccccagccaggt
R K S E A R D P G D L W L V E I P Q P G
gatttctggtgtgggggggaccttcccaggcctaaggtgccctctggagggaacta
D F W C G G G P F P G P K V P L W R D L
ctttaaatt
L - N

```

Figure 2. Nucleotide sequence and deduced amino acid sequence of ADO cDNA in common carp *Cyprinus carpio*. The one with the asterisk (*) is the predicted N-glycosylation sites in ADO (Genbank accession number: MK035000).

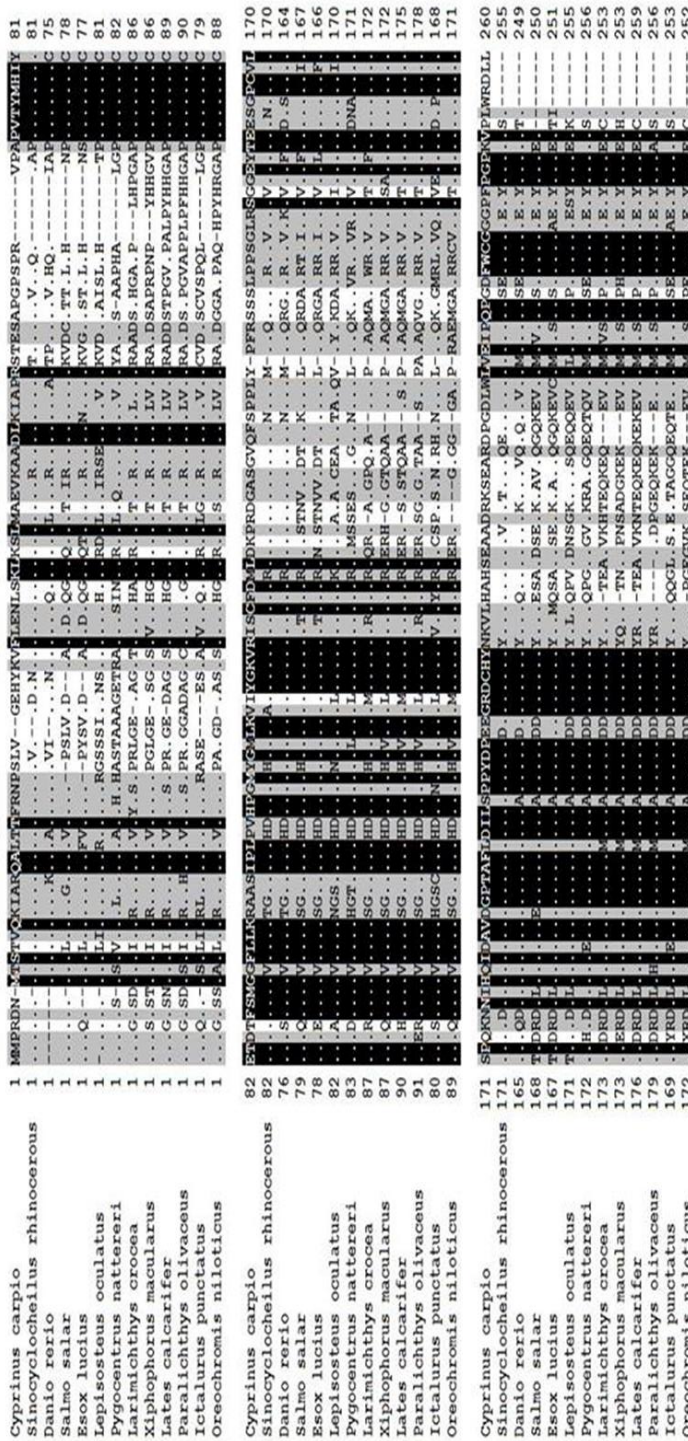

Figure 3. Alignment of ADO deduced amino acids with other organisms. The conserved region of the amino acid sequences are in dark color. GeneBank accession number: *Sinocyclocheilus rhinoceros* (XP_016399656), *Danio rerio* (NP_998358), *Salmo salar* (XP_014060776), *Esox lucius* (XP_010868171), *Lepisosteus oculatus* (XP_006630446), *Pygocentrus nattereri* (XP_017549864), *Larimichthys crocea* (XP_010750130), *Xiphophorus maculatus* (XP_005806180), *Lates calcarifer* (XP_018516308), *Paralichthys olivaceus* (XP_019969282), *Ictalurus punctatus* (XP_017332680), *Oreochromis niloticus* (XP_005473824) and *Cyprinus carpio* (MK035000).

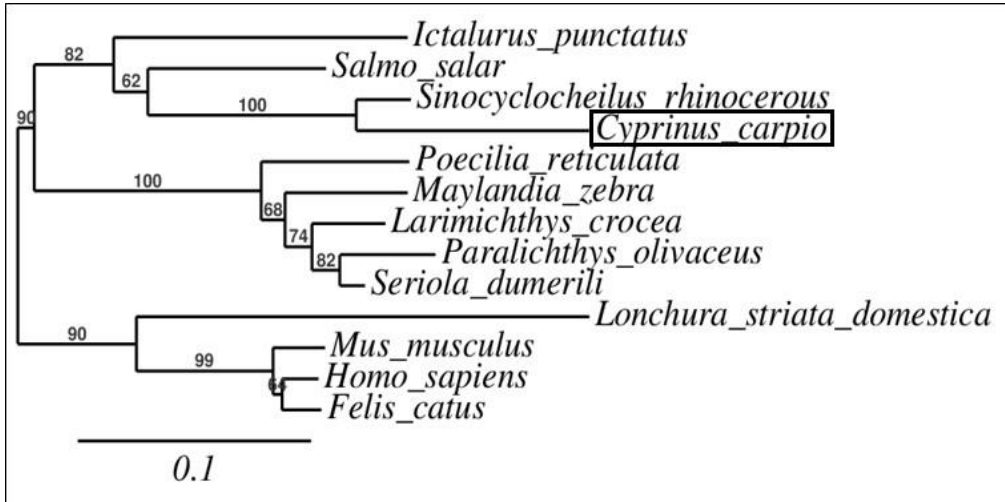

Figure 4. Phylogenetic tree of ADO by the neighbor-join method. GeneBank accession no: *Ictalurus punctatus* (XP_017332680.1), *Salmo salar* (NP_001134267.1), *Sinocyclocheilus rhinoceros* (XP_016399656.1), *Poecilia reticulata* (XP_017166122.1), *Maylandia zebra* (XP_004570438.1), *Larimichthys crocea* (KKF18981.1), *Paralichthys olivaceus* (XP_019939118.1), *Seriola dumerili* (XP_022621764.1), *Lonchura striata domestica* (XP_021391450.1), *Mus musculus* (AAH58407.1), *Homo sapiens* (NP_116193.2), *Felis catus* (XP_003994017.3), and *Cyprinus carpio* (MK035000).

Quantitative-PCR and tissue distribution

Hepatopancreas, brain, gills, intestine, muscles, eye, heart, spleen, kidney, and gallbladder were the organ samples for q-PCR. All organ samples had bands indicating that ADO is present in juvenile common carp (Figure 5). The highest level of ADO being expressed was found in the hepatopancreas followed by the brain (Figure 6).

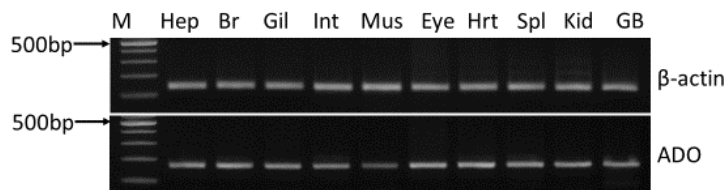

Figure 5. The result of RT-PCR using gel electrophoresis. M, marker; hep, hepatopancreas; br, brain; Gil, gills; Int, intestine; Mus, muscles; Eye, eye; Hrt, heart; Spl, spleen, Kid, kidney; and GB, gallbladder.

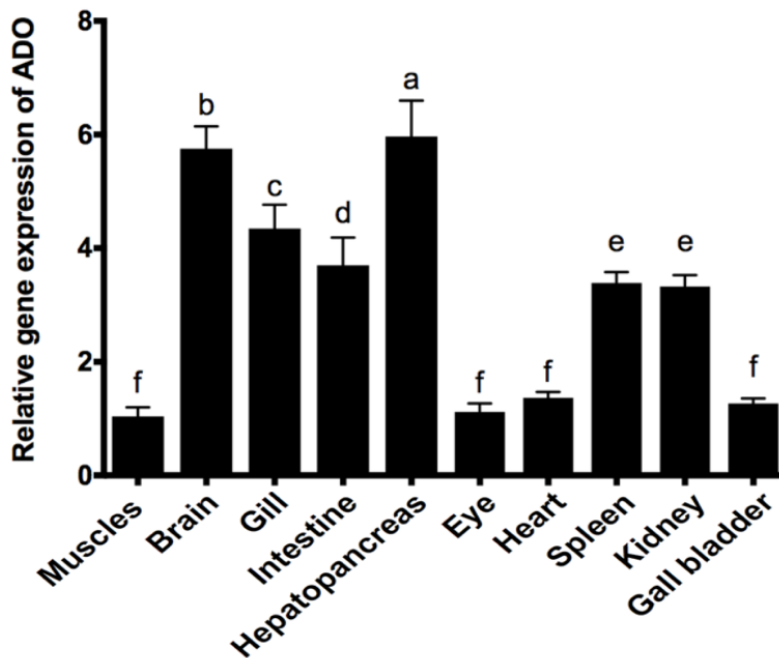

Figure 6. Relative gene expression of ADO gene in different organs of juvenile common carp. Samples were normalized using β -actin ($n=5$). (Graphs represents mean \pm SD; values with the different superscript letters are significantly different ($P<0.05$) ($n=5$) by Tukey's test).

DISCUSSION

The presence of conserved tyrosine and cysteine in DUF1637 is important for the structure of the ADO genes. Tyrosine has a tendency to form hydrogen bonds with that of the mainchain within edge strands. While cysteine is important in making hydrogen bonds with the mainchain NH functions in the N-terminal regions of α -helices (Worth and Blundell 2010). The N-linked glycosylation site that is present in common carp, on the other hand, is responsible for the attachment of oligosaccharides to a nitrogen atom, usually the N4 of asparagine residues (Marshall 1972). In addition, the N-glycosylation occurs mainly on secreted or membrane bound proteins and affects the solubility and stability of ADO.

The difference in methods used in detecting the presence and level of cysteamine and the species of fish affects results of tissue distribution and gene expression level of ADO. In the study conducted by Kataoka et al. (1988)

utilizing the gas chromatography, ADO was present in brain, gills, and liver but undetected in intestine and muscles of mackerel. The present study used Q-PCR hence ADO was detected also in muscles and intestine and other organs of common carp.

The ADO gene expression level was significantly high in the liver of cobia *Rachycentron canadum* which was around 2% expression compared to reference gene beta-actin for each diet (% taurine) (Watson et al. 2015). This support our result that ADO was also high in hepatopancreas of common carp.

We still yet to prove if ADO is an important enzyme/ gene for taurine production in common carp. The future application of this study begin once proven that ADO is a significant enzyme for taurine production. By cloning this gene and performing transgenesis to other fish to improve taurine production we could increase the ability of fish to utilize plant base protein hence utilization of fishmeal for feed production could be reduced.

Since this study is a basic study on the taurine synthesizing enzymes in juvenile common carp, in-depth study on the physiological and nutritional function of ADO on common carp should be conducted to further understand the taurine production and the role of taurine synthesizing enzymes in common carp.

ACKNOWLEDGEMENTS

This work was financially supported by Grant in Aid for Challenging Exploratory Research (25660165) from the Japanese Society for Promotion of Science. The first author is supported by a scholarship from the Ministry of Education, Culture, Sports, Science and Technology (MEXT) in Japan. The authors are grateful to Mrs. Reiko Nozaki, Laboratory of Genome Science, TUMSAT for her technical support for sequencing. The comments and suggestions of two anonymous reviewers helped improved the manuscript.

REFERENCES

- Altschul SF, Gish W, Miller W, Myers EW and Lipman DJ. 1990. Basic local alignment search tool. *Journal of Molecular Biology*, 215: 403-410.
- Chang YC, Ding ST, Lee YH, Wang YC, Huang MF and Liu IH. 2013. Taurine homeostasis requires de novo synthesis via cysteine sulfinic acid decarboxylase during zebrafish early embryogenesis. *Amino Acids*, 44: 615–629.

- Goto T, Takagi S, Ichiki T, Sakai T, Endo M, Yoshida T, Ukawa M and Murata H. 2001a. Studies on the green liver in cultured red sea bream fed low level and non-fish meal diets: relationship between hepatic taurine and biliverdin levels. *Fisheries Science*, 67: 58–63.
- Goto T, Matsumoto T and Takagi S. 2001b. Distribution of the hepatic cysteamine dioxygenase activities in fish. *Fisheries Science*, 67: 1187–1189.
- Goto T, Matsumoto T, Murakami S, Takagi S and Hasumi F. 2003. Conversion of cysteate into taurine in liver of fish. *Fisheries Science*, 69: 216–218.
- Griffith OW. 1987. Mammalian sulphuramino acid metabolism: an overview. In: Jakoby WB and Griffith OW (eds). *Methods in Enzymology*. Vol. 143. Academic Press, New York. pp. 366-376.
- Haga Y, Kondo H, Kumagai A, Satoh N, Hirono I and Satoh S. 2015. Isolation, molecular characterization of cysteine sulfinic acid decarboxylase (CSD) of red sea bream *Pagrus major* and yellowtail *Seriola quinqueradiata* and expression analysis of CSD from several marine fish species. *Aquaculture*, 449: 8-17.
- Higuchi M, Celino FT, Miura C and Miura T. 2012. The Synthesis and Role of Taurine in the Eel Spermatogenesis. In: Kawaguchi M, Misaki K, Sato H, Yokokawa T, Itai T, Nguyen TM, Ono J and Tanabe S (eds). *Interdisciplinary Studies on Environmental Chemistry—Environmental Pollution and Ecotoxicology*. Center for Marine Environmental Studies, Ehime University, Japan. © by TERRAPUB, pp. 35-40.
- Huxtable RJ. 1992. Physiological actions of taurine. *Physiology Review*, 72: 101–163.
- Jacobsen JG and Smith LH. 1968. Biochemistry and physiology of taurine and taurine derivatives. *Physiology Review*, 48: 424-511.
- Kataoka H, Ohishi K, Imai J and Mukai M. 1988. Distribution of cysteamine dioxygenase in animal tissue. *Agricultural and Biological Chemistry*, 52(6): 1611-1613.
- Larkin MA, Blackshields G, Brown NP, Chenna R, McGettigan PA, McWilliam H, Valentin F, Wallace IM, Wilm A, Lopez R, Thompson JD, Gibson TJ and Higgins DG. 2007. ClustalW and ClustalX version 2. *Bioinformatics*, 23(21): 2947-2948.
- Livak KJ and Schmittgen TD. 2001. Analysis of relative gene expression data using real-time quantitative PCR and the $2^{-\Delta\Delta Ct}$ method. *Methods*, 25: 402–408.
- Marshall RD. 1972. Glycoproteins. *Annual Review in Biochemistry*, 41: 673-702. DOI: 10.1146/annurev.bi.41.070172.003325
- Saitou N and Nei M. 1987. The Neighbor-Joining method—a new method for reconstructing phylogenetic trees. *Molecular Biology and Evolution*, 4: 406-425.

- Stipanuk MH. 2004. Sulfur amino acid metabolism: pathways for production and removal of homocysteine and cysteine. *Annual Review in Nutrition*, 24: 539-577.
- Stipanuk MH and Ueki I. 2011. Dealing with methionine/homocysteine sulfur: cysteine metabolism to taurine and inorganic sulfur. *Journal of Inherited Metabolic Disease*, 34(1): 17–32.
- Tevatia R, Allen J, Rudrappa D, White D, Clemente T, Cerutti H, Demirel Y and Blum P. 2015. The taurine biosynthetic pathway of microalgae. *Algal Research*, 9: 21–26. DOI: 10.1016/j.algal.2015.02.012
- Wang X, He G, Mai K, Xu W and Zhou H. 2015. Ontogenic taurine biosynthesis ability in rainbow trout (*Oncorhynchus mykiss*). *Comparative Biochemistry and Physiology*, 185B: 10-15.
- Wang X, He G, Mai K, Xu W and Zhou H. 2016. Differential regulation of taurine biosynthesis in rainbow trout and Japanese flounder. *Scientific Report*, 6: 21231. DOI:10.1038/srep21231.
- Watson A, Barrows F and Place A. 2015. The importance of taurine and n-3 fatty acids in Cobia, *Rachycentron canadum*, *Nutrition*. *Bulletin of Fisheries Research Agency*, 40 :51-59.
- Worth CK and Blundell TL. 2010. On the evolutionary conservation of hydrogen bonds made by buried polar amino acids: the hidden joists, braces and trusses of protein architecture. *BMC Evolutionary Biology*, 10: 161. DOI: 10.1186/1471-2148-10-161.
- Yokoyama M and Nakazoe J. 1991. Effects of dietary protein levels on free amino acid and glutathione content in the tissue of rainbow trout. *Comparative Biochemistry and Physiology*, 99B: 203-206.
- Yokoyama M, Takeuchi T, Park GS and Nakazoe J. 2001. Hepatic cysteinesulphinatase decarboxylase activity in fish. *Aquaculture Research*, 32(Suppl.1): 216-220.

ARTICLE INFO

Received: 23 August 2018

Revised: 07 October 2018

Accepted: 20 October 2018

Available online: 30 October 2018

Responsible Editor

Christopher Marlowe A. Caipang, PhD

Role of authors: MMGP – conducted the study, analyzed the data, and wrote the manuscript; YH – conceptualized the study and helped write the manuscript; HK – conceptualized the study and assisted in the conduct of molecular experiment; IH – assisted in the conduct of Q-PCR experiment; SH- secured the grant and helped design and conduct the experiment.

Spatial and temporal distribution, Size composition, and Abundance of Oval squid, *Sepioteuthis lessoniana* (Lesson 1830) in the coastal waters of Bolong, Zamboanga City, Philippines

Jesus Rolando A. Samson

College of Fisheries and Food Sciences, Zamboanga State College of Marine Sciences and Technology, Fort Pilar, Zamboanga City, Philippines.

Correspondence: rolandosamson@yahoo.com

<https://doi.org/10.69721/TPS.J.2019.11.1.03>

ABSTRACT

The study was conducted in the coastal waters of Bolong, Zamboanga City, Philippines purposely to determine the spatial distribution of *Sepioteuthis lessoniana* in relation to the depth of water and temporal distribution in relation to lunar phase using size composition and catch per unit effort (CPUE) data. Two sampling stations were established, namely, shallow-water station (Station 1) and deep-water station (Stations 2). Twenty units of squid traps were utilized in the study; ten of which were set in Station 1 and the other ten in Station 2. The traps were constructed using bamboo and green polyethylene netting. Instead of bait, coconut spikelet was placed inside the trap to lure squids. A motorized banca was used to set and haul the traps in the two sampling stations. Although hauling was done daily, sampling is scheduled only 12 times a month with three samplings per lunar phase. Catches were segregated according to sampling stations and lunar phases. Results of the study revealed that the squids caught in deeper waters were significantly larger than those caught in shallow waters, and that females dominated the shallow waters while males dominated the deeper waters. Furthermore, the catch during Full Moon was significantly higher than the catch of the other three lunar phases ($p < 0.05$) with highest CPUE recorded in Station 2 during Full Moon ($0.352 \text{ kg trap}^{-1} \text{ day}^{-1}$).

Keywords: Spatial distribution, temporal distribution, squid strap, CPUE

INTRODUCTION

Sepioteuthis lessoniana (Lesson 1830), commonly known as the oval squid or bigfin reef squid, is a commercially important species of loliginid squid. This species of squid preys on live fish and crustaceans. They have eight arms and two tentacles, the latter for capturing prey and guiding it to their sharp beaks. They move by "jet propulsion", sucking water into a muscular sac in the mantle cavity surrounding their bodies and quickly expelling it out a narrow siphon.

Squid together with cuttlefish, octopus, crabs, groupers, ornamental fish, roundscad and sea cucumber constitute the other major fishery exports, contributing 34.5% or US\$440 million of the total US\$1,268 million export revenues in the Philippines (Philippines Fisheries Profile 2014). Unfortunately, information on catch and distribution of this species are limited and often unavailable. Voss (1963) wrote the first extensive report on the taxonomy of Philippine Cephalopods. Subsequently, Flores (1974) surveyed the traditional fishing grounds and identified some fishing gears and furthermore, Hernando and Flores (1981) described the different squid fishing gears used in the country and contributed information in terms of species identification, fishing seasons, and production. Accordingly, there are four genera and seven species of the squid species in the Philippines with *S. lessoniana* as one of the most common. In the Philippines, *S. lessoniana* is caught mainly by trawl (Hernando and Flores 1981). Regrettably, its contribution to the annual Philippine cephalopod catch of about 10,000 tons (Balgos 1990) is not known, owing to the lack of species-specific data. Few other studies were performed on *Loligo duvauceli* in Indian waters (Chakraborty et al. 1997; Karnik et al. 2003; Meiyappan and Srinath 1989; Mohamed and Rao 1997; Neethiselvan and Venkataramani 2002; Silas et al. 1986).

In the coastal waters of Bolong, catching *S. lessoniana* using squid trap became a very viable source of income for many of the fishermen living in the area. However, despite the importance of this species to the people, very little attention has been done to study the spatial and temporal distribution of this species. There has been one related preliminary study conducted for *S. lessoniana* that is the study of Balgos and Pauly (1998) in Philippine waters. However, spatial and temporal distribution were not clearly defined in that study. In fact, what was stated is that the *S. lessoniana* is an important fisheries species throughout much of its range, from central Japan and the Red Sea in the north, through South and South-East Asia, to Queensland, Australia, and North Island, New Zealand, in the south (Roper et al. 1984).

There are other studies conducted on wild squid populations but on size-at-age between geographical areas (Jackson and Moltschaniwskyj 2002; Chen and Chiu 2003) and between seasonal cohorts (Arkhipkin et al. 2000; Villegas 2001; Pecl 2004). Accordingly, the differences in growth were mainly attributed to the geographical or seasonal prevailing temperatures during the early life stages. Currently, no formal assessment of this resource is undertaken. Some exercises with cohort analysis (Royer et al. 2002; Challier et al. 2006) and depletion methods (Young et al. 2004) have been conducted for loliginid squids, but for the most part, conventional models used in the assessment of finfish stocks are not applicable (Pierce and Guerra, 1994). Nevertheless, if stock size predictions are to rely partly on temperature data (Robin and Denis 1999; Pierce and Boyle 2003; Chen et al. 2006), the

understanding of age structure, growth, and its variability under fluctuating environmental conditions is of fundamental relevance.

Hence, the present study was carried out in order to investigate the spatial and temporal distribution of the squid *S. lessoniana* in the coastal waters of Bolong with a view to obtain basic scientific information relevant to management of its fishery. Specifically, the study aims to determine the spatial distribution of *S. lessoniana* in relation to the depth of water and temporal distribution in relation to lunar phase using size composition, CPUE data, and food and feeding habits.

METHODS

Study Site

The study was conducted in the coastal waters of Bolong, approximately 30 km from the Zamboanga City proper (Figure 1). The shoreline in the area was mainly muddy with sandy beach. Two sampling stations were established in the study site. The exact location of the sampling stations was determined using a Global Positioning System (GPS). Station 1 is situated at 07° 03' 45" N and 122° 13' 15" E. Station 2 situated at 07° 01' 15" N and 122° 14' 45" E. The depth of the water in Station 1 ranged from 6 to 10 m, while in Station 2, the water depth ranged from 11 to 15 m.

The estimated area of each sampling station was 2.5 km². The substrates of the two sampling stations were mostly muddy and sandy. Based on the interviews with the squid trap operators in the study area, they set their traps in water depths ranging from 6-15 m, and they considered the depths ranging from 6-10 m as shallow waters and 11-15 m as deep waters.

Construction, Setting and Hauling of Squid Traps

Twenty units of squid traps were constructed using bamboo and green polyethylene netting. Instead of bait, coconut spikelet was placed inside the trap to lure squids (Figure 2).

These squid traps, which measure 1.00 m x 0.75 m x 0.60 m, were capable of catching squid particularly oval squid with the use of coconut spikelet as an attractant instead of baits. The squid traps were known to be environment friendly considering that squids caught by this fishing gear were considered marketable in size ranging from 110 mm to 220 mm.

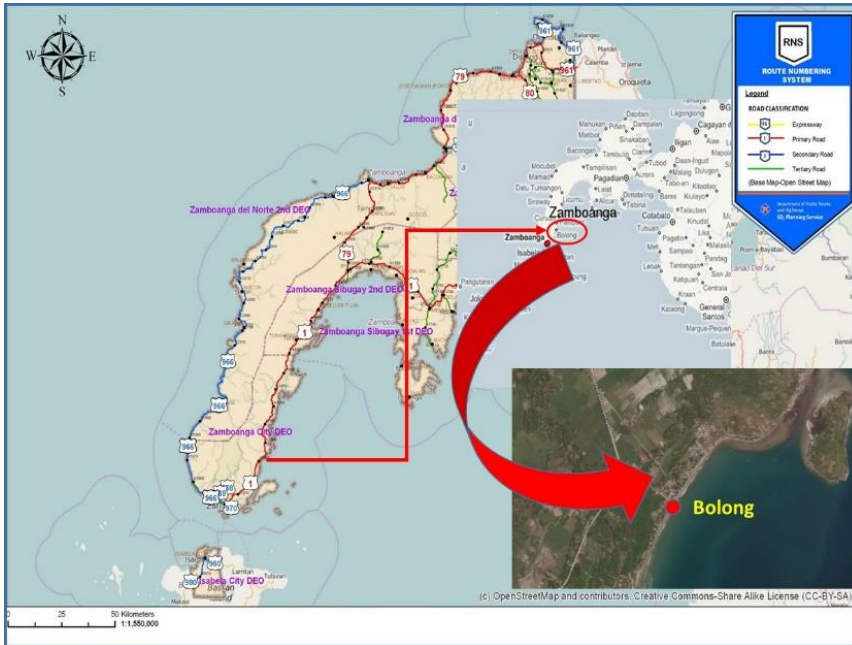

Figure 1. A map showing the location of Bolong, Zamboanga City.

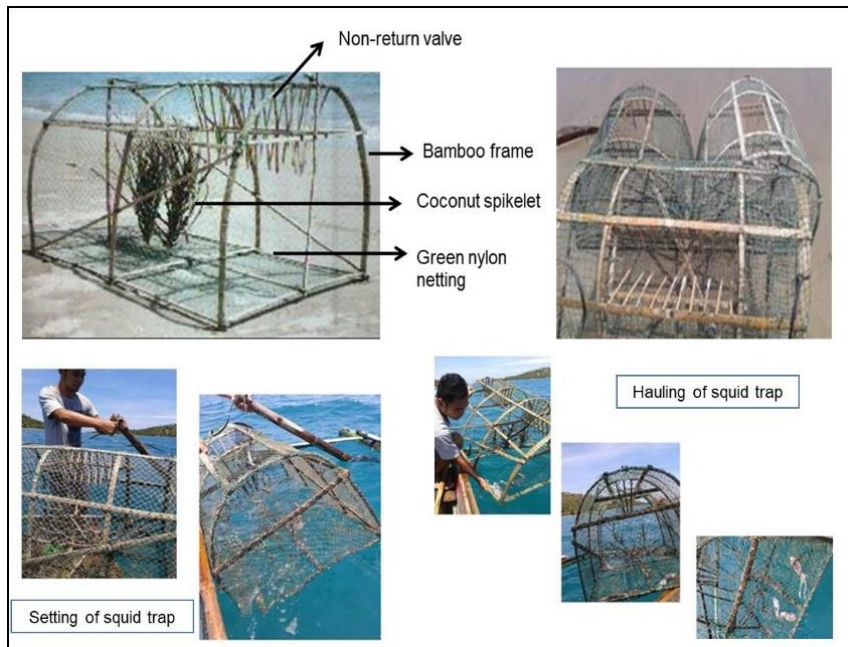

Figure 2. The squid traps used in the study.

Ten traps were set in Station 1 and the other 10 in Station 2. The traps were positioned approximately 1 m away from the bottom. Each trap was attached using a rope to a bamboo pole set perpendicularly to the bottom. The reason why the traps were set 1 m from the bottom was to avoid being covered with mud as the area has a muddy bottom and to avoid being wrapped with algae “lumut”. Damaged/lost traps were replaced immediately.

In the shallow water (Station 1), two traps were set starting in 6 m depth, another two were set in the 7 m depth and so forth until the 10 m depth. Likewise, in the deeper waters (Station 2), two traps were set starting at the 11 m depth, two in the 12 m depth and so forth until the 15 m depth. A motorized banca was used to set and haul the traps in the two sampling stations. Hauling is scheduled daily between 0600-0800H.

Field Sampling

Two groups of *S. lessoniana* were sampled. The first group comprises those caught in Station 1 and the other group in Station 2. Although hauling was done daily, sampling was scheduled only 12 times a month with three samplings per lunar phase, i.e., New Moon, First Quarter, Full Moon, and Last Quarter.

Spatial Distribution

Although the traps were set according to specific depth, catches were grouped according to sampling stations. Males were also segregated from the females in both stations. After the segregation, the mantle length and the corresponding weight were measured and recorded. Comparative analysis between the catch (kg) of the oval squid in the two sampling stations was conducted using t-test of independent sample to determine if significant difference exists (Pagano 2004).

Temporal Distribution

In order to determine the temporal distribution, the catch data were grouped according to lunar phase, i.e., New Moon, First Quarter, Full Moon, and Last Quarter. Comparative analysis was conducted according to lunar phase using Analysis of Variance (ANOVA) to determine if significant differences exist. Post hoc analysis was also done using Duncan Multiple Range Test (Duncan 1955).

Catch-per-unit-effort (CPUE)

Catch data collected (including effort) on a weekly basis were grouped on a monthly basis. Catch-per-unit-effort (CPUE) was determined following the equation:

$$\text{CPUE} = \frac{\text{Total catch (kg)}}{\text{No. of gear units x day}}$$

In a study conducted by Chen et al. (2002), squid catch was compiled in a geographically referenced format using a statistical grid of 0.5° (0.5°longitude by 0.5°latitude). The catch per unit effort (CPUE, t/vessel/d) of squid was standardized using a relative CPUE comparison method (Salthaug and Godø 2001). Then the adjusted CPUE was used as an index of squid abundances to illustrate the spatiotemporal patterns of population dynamics. In this study, however, this model was not adopted due to limited information in time and space.

RESULTS

Spatial Distribution

Three hundred thirty-two (332) individuals of *S. lessoniana* were caught using squid traps in the coastal waters of Bolong from August to October 2017 with a total weight of 134.94 kg (Table 1). The total catch recorded in Station 1 was 55.88 kg (41.41%) and the total catch in Station 2 was 79.06 kg (58.59%). While higher catch of female squid was recorded in Station 1 (31.01 kg) as compared to the males (24.87 kg), higher catch of males was recorded in Station 2 (45.81 kg) as compared to the females (33.25 kg).

Table 1. Monthly catch of male and female *S. lessoniana* by sampling station (M - male; F - female).

Months (2017)	Monthly Catch (kg)						
	Station 1			Station 2			Pooled
	M	F	Total	M	F	Total	
Aug	8.92	10.05	18.97	14.74	11.05	25.79	44.76
Sep	8.34	11.60	19.94	14.96	10.89	25.85	45.79
Oct	7.61	9.36	16.97	16.11	11.31	27.42	44.39
Total	24.87	31.01	55.88	45.81	33.25	79.06	134.94

Temporal Distribution

The catch of *S. lessoniana* relative to the different phases of the moon is shown in Table 2. Full Moon registered the highest catch (51.80 kg) with mean weight of 492.60 g. New moon recorded the second highest catch (34.43 kg), with mean weight of 412.99 g. First Quarter was third with 26.76 kg with mean weight of 350.19 g. The lowest catch happened in the Last Quarter (21.97 kg), with mean weight of 307.14 g.

Table 2. Monthly catches (kg) and mean body weights (g) of *S. lessoniana* by lunar phase in 2017.

Lunar Phases	Monthly Catches (kg)			Total (kg)	Mean Body Weight (g)
	Aug	Sep	Oct		
First Quarter	8.29	8.88	9.59	26.76	350.19
Full Moon	18.06	16.84	16.88	51.78	492.60
Last Quarter	7.00	8.39	6.58	21.97	307.14
New Moon	11.41	11.68	11.34	34.43	412.99
Total	44.76	45.79	44.39	134.94	Ave: 390.73

Duncan's Multiple Range Test (DMRT) reveal significant difference among the mean weights of the four different lunar phases with p value less than 0.05 (Table 3).

Table 3. DMRT among moon phases in terms of mean weights of *S. lessoniana*. Note: All means having the same letter are not significant at $\alpha=0.05$

Moon Phases	Mean Weight (g)	Notation
Full Moon	492.60	a
New Moon	412.99	b
First Quarter	350.19	c
Last Quarter	307.14	c

Further analysis reveal that significant difference exists between the mean weights of squid caught during Full Moon (492.60 g) against the other three moon phases. Significant difference also exists between the mean weights of squid caught during New Moon (412.99 g) and the other two moon phases (First and Last Quarter) whose mean weights are 350.19 g and 307.14 g, respectively. No significant difference, however, exists between the First and Last Quarter ($p>.05$).

Size Composition

The mean mantle length of *S. lessoniana* was recorded at 194.29 mm with 73% of the squid in the range 110-240 mm. The males registered a mean mantle length of 192.52 mm and females 196.54 mm, with 76% of the male within the length ranges of 110-240 mm and the females within 160-220 mm.

The mean weight of *S. lessoniana* for all stations was 405.99 g with males registering a mean weight of 397.14 g and females 416.16 g. August registered a mean weight of 382.62 g, September with 407.37 g, and October with 431.02 g. In Station 1, the males registered a mean weight of 304.78 g while the females recorded 382.95 g. In Station 2, the males registered a mean weight of 436.31 g while the females recorded 455.53 g. Although the total catch of male squids in Station 2 was higher than the females, the female squids were bigger than the males in both Stations 1 and 2 (Figure 3).

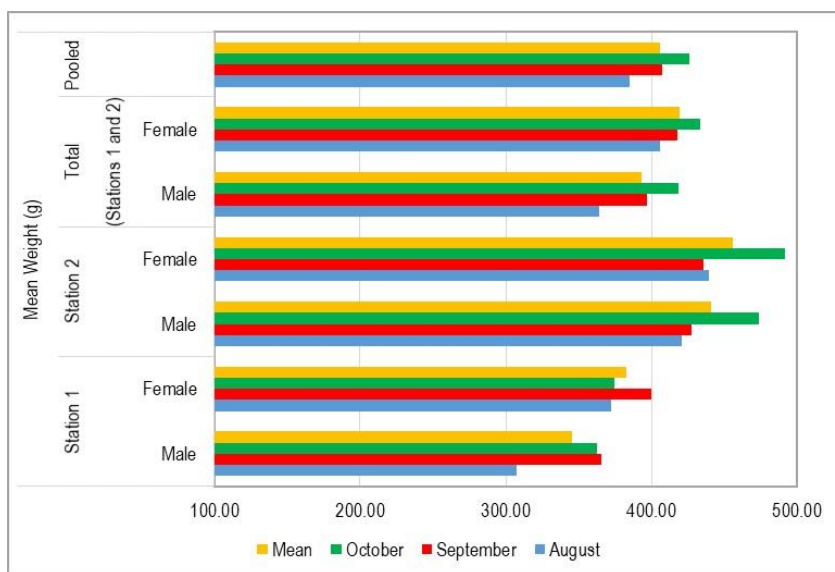

Figure 3. Monthly mean weight (g) distribution of *S. lessoniana* by sampling station.

Abundance

The abundance of oval squid was analyzed in terms of the catch-per-unit-effort (CPUE). The CPUE for the two sampling stations was recorded at 0.188 kg trap⁻¹ day⁻¹, with the highest monthly CPUE recorded in Station 2 in the month of October with a mean CPUE of 0.229 kg trap⁻¹ day⁻¹, while the lowest was recorded in Station 1 of the same month with 0.155 kg trap⁻¹ day⁻¹.

Furthermore, results of the mean catch-per-unit-effort (CPUE) according to the four different moon phases reveal that the highest CPUE was recorded in Station 2 during Full Moon ($0.352 \text{ kg trap}^{-1} \text{ day}^{-1}$) and the lowest was recorded in Station 1 during First and Last Quarters with $0.107 \text{ kg trap}^{-1} \text{ day}^{-1}$ and $0.110 \text{ kg trap}^{-1} \text{ day}^{-1}$, respectively (Figure 6). The results further showed the highest CPUEs were recorded during Full Moon in both sampling stations, and lowest CPUEs were recorded during the Last Quarter in both sampling stations.

DISCUSSION

There is a possibility that the 3-month data obtained in this study (August-October) will be the same if conducted in other months considering that *S. lessoniana* are abundantly found in the area year round as claimed by the fishermen. The results where the findings reveal that female squids are abundantly found in the shallow waters concur with the findings of Segawa (1987). The reason behind this is female squids prefer shallow waters with twigs and other rough surfaces where they can easily attach their egg capsules. This justifies why in this study, male squids were abundantly found in the deeper waters (Station 1) as compared to females, which is contrary to the observation made by Segawa (1987) in Kominato and adjacent waters of central Honshu, Japan, where the females dominated the males.

The findings of the study on the mantle length of *S. lessoniana* in this study also concur with the findings reported in the study by Sivashanthini et al. (2009) in Jaffna lagoon, Sri Lanka. In the present study, the mean mantle length of *S. lessoniana* was recorded at 194.29 mm with 73% of the squid in the range 110-240 mm. The males registered a mean mantle length of 192.52 mm and females 196.54 mm, with 76% of the male within the length ranges of 110-240 mm and the females within 160-220 mm. In the length-weight relationship conducted by Sivashanthini et al. (2009), the size of the mantle length of *S. lessoniana* ranged from 38-255 mm with mean mantle length of 137.30 mm. The mantle length of males ranged from 55-255 mm with mean mantle length of 138.90 mm. The mantle length of females ranged from 38-248 mm with mean mantle length of 135.80 mm. Although in the present study the female squids are significantly bigger than the male squids, no significant difference exists in the study of Sivashanthini et al. (2009) despite of same result where the females *S. lessoniana* are bigger than the males.

The dominance of female oval squids in Station 1 is a manifestation that female *S. lessoniana* prefer shallow waters where there are twigs and other objects for them to attach their egg capsules. Segawa et al. (1993) also made the same observation in in Ishigaki Island, Okinawa, southwestern Japan. His findings show that female *S. lessoniana* are abundantly found in

shallow waters where they lay their eggs in *Sargassum* beds. In the study of Chen et al. (2006), time-series maps of squid abundances against the background of sea surface temperature (SST) for the same period were created to visually analyze and depict spatial and temporal patterns of squid abundances, and changes in abundances relative to changes in SST. Spatial correlations between squid abundances and SST were calculated using Spearman's rank correlation for the monthly grid data set. Furthermore, a time series analysis was applied to investigate the temporal autocorrelations of environmental variables.

Sepioteuthis lessoniana can lay eggs year round but the major spawning season may vary according to location. Spawning may occur as early as January in warmer waters, while in cooler waters near Japan, spawning can begin as late as September. Females lay their eggs in single straight strands on rocks, corals, plants, submerged branches, and other surfaces along shorelines. After laying eggs, the body of the female usually deteriorates and dies before she can mate again (Segawa et al. 1993) On the other hand, the male can usually mate with several more females before he dies (Sivashanthini et al. 2009; Ikeda et al. 2009; Jereb and Roper 2006; Wada et al. 2005). This explains the dominance of female *S. lessoniana* in the shallow waters (Station 1) and the dominance of males in the deeper waters as observed in the present study. Hence, the spatial distribution of female *S. lessoniana* is comparatively higher in the shallow waters while the spatial distribution of the males is higher in the deeper waters.

It has also been observed that higher catch and bigger squids were recorded during Full Moon with 51.78 kg and 492.60 g, respectively. It has also been observed that the highest mean CPUEs were recorded during Full Moon (0.288 kg trap⁻¹ day⁻¹) and New Moon (0.191 kg trap⁻¹ day⁻¹). These findings may imply that the temporal distribution of *S. lessoniana* is higher during Full Moon and New Moon.

In general, oval squids were abundantly found in the deeper waters of Bolong, Zamboanga City during Full Moon and lowest in the shallow waters during the First and Last Quarter. Specifically, however, female oval squid preferred shallow waters where they can easily attach their egg capsules during spawning. Furthermore, significant difference exists between the mean weight of oval squid in the deeper waters and shallow waters. Significant difference also exists among moon phases, with Full Moon registering the highest mean weight. Moreover, field observations revealed that oval squid forms the most important fishery in the coastal waters of Bolong, Zamboanga City. Hence, catching oval squid became a viable source of income for many of the fishermen living in the area.

ACKNOWLEDGEMENTS

The authors' sincerest thanks are due to the barangay officials of barangay Bolong for their assistance particularly in facilitating the conduct of this research. The author is also pleased to acknowledge the considerable assistance given by the fishermen in the area, most especially the squid trap operators. Special thanks are also due to the two reviewers of this paper for their substantial insights, suggestions and recommendations.

REFERENCES

- Arkhipkin AI, Jereb P and Ragonese S. 2000. Growth and maturation in two successive seasonal groups of the short-finned squid, *Illex coindetii* from the Strait of Sicily (central Mediterranean). ICES Journal of Marine Science, 57: 31-41.
- Balgos MC and Pauly D. 1998. Age and growth of the squid *Sepioteuthis lessoniana* in N. W. Luzon, Philippines. South African Journal Marine Science, 20: 449-452.
- Balgos MC. 1990. Age and growth of the squid *Sepioteuthis lessoniana* Lesson 1830 in Bolinao Pangasinan by statolith observation and length frequency analysis. M.Sc. Thesis, University of the Philippines, Quezon City. 78 pp.
- Chakraborty SK, Deshmukh VD, Khan MZ, Vidyasagar K and Raje SG. 1997. Estimation of growth, mortality, recruitment pattern and maximum sustainable yield of important fishery resources of Maharashtra coast. Indian Journal Marine Sciences, 26: 53-56.
- Challier L, Orr P and Robin J-P. 2006. Introducing inter-individual growth variability in the assessment of a cephalopod population: application to the English Channel squid *Loligo forbesi*. Oecologia, 150: 17-28.
- Chen CS, Shiao MS and Chiu TS. 2002. Growth of Argentine shortfin squid, *Illex argentinus*, in the Southwest Atlantic during its post-recruitment migration. Acta Oceanographica Taiwanica, 40: 33-46.
- Chen C and Chiu T. 2003. Variations on life history parameters in two geographical groups of neon flying squid, *Ommastrephes bartramii*, from the North Pacific. Fisheries Research, 63: 349-366.
- Chen CS, Pierce GJ, Wang J, Robin J-P, Poulard JC and Pereira J. 2006. The apparent disappearance of *Loligo forbesi* from the south of its range in the 1990s: trends in *Loligo* spp. abundance in the northeast Atlantic and possible environmental influences. Fisheries Research, 78: 44-54.
- Duncan DB. 1955. Multiple range and multiple F tests. Biometrics, 11(1): 1-42. DOI: 10.2307/3001478
- Flores EC. 1974. Studies on squids 1. A survey of Philippine traditional squid fishing grounds. University of the Philippines. Marine Fisheries Technical Report No. 2, 12 pp.

- Hernando Jr AM and Flores EC. 1981. The Philippine squid fishery: A review. *Marine Fishery Review*, 43(1): 13-20.
- Ikeda Y, Ueta Y, Anderson F and Matsumoto G. 2009. Reproduction and life span of the oval squid *Sepioteuthis lessoniana* (Cephalopoda: Loliginidae): comparison between laboratory-cultured and wild-caught squid. *Marine Biodiversity Records*, 2: 1-7.
- Jackson GD and Moltschanivskyj NA. 2002. Spatial and temporal variation in growth rates and maturity in the Indo-Pacific squid *Sepioteuthis lessoniana* (Cephalopoda: Loliginidae). *Marine Biology*, 140: 747-754.
- Jereb P and Roper C. 2006. Cephalopods of the Indian Ocean. A review. Part I. Inshore squids (Loliginidae) collected during the International Indian Ocean Expedition. *Proceedings of the Biological Society of Washington*, 119(1): 91-136.
- Karnik NS, Chakraborty SK, Jaiswar AK, Swamy RP, Rajaprasad R, Boomireddy S and Rizvi AF. 2003. Growth and mortality of Indian squid, *Loligo duvauceli* (Mollusca/ Cephalopoda/Teuthoidea) from Mumbai waters, India. *Indian Journal Marine Sciences*, 32(1): 67-70.
- Meiyappan MM and Srinath M. 1989. Growth and Mortality of Indian Squid (*Loligo duvauceli*) off Cochin, India, In: Venema SC and van Zalinge NP (eds). *Contribution to Tropical Fish Stock Assessment in India*. FAO, Rome, 14pp.
- Mohamed SK and Rao GS. 1997. Seasonal growth, stock recruitment and prediction of yield of Indian squid *Loligo duvauceli* exploited from Karnataka coast. *Indian Journal Fisheries*, 44: 319-329.
- Neethiselvan N and Venkataramani VK. 2002. Population dynamics of siboga squid *Doryteuthis sibogae* (Cephalopoda/Teuthoidea) in Thoothukkudi (Tuticorin) coast, southeast coast of India. *Indian Journal. Marine Sciences*, 31: 213-217.
- Pagano RR. 2004. *Understanding Statistics in the Behavioral Sciences* (7th ed.). Thomson/Wadsworth, Australia. 562pp.
- Pecl GT. 2004. The in situ relationships between season of hatching, growth and condition in the southern calamary, *Sepioteuthis australis*. *Marine and Freshwater Research*, 55(4): 429-438.
- Philippine Fisheries Profile. 2014. Bureau of Fisheries and Aquatic Resources. www.bfar.da.gov.ph.
- Pierce GJ and Boyle PR. 2003. Empirical modelling of interannual trends in abundance of squid (*Loligo forbesi*) in Scottish waters. *Fisheries Research*, 59: 305-326.
- Pierce GJ and Guerra A. 1994. Stock assessment methods used for cephalopod fisheries. *Fisheries Research*, 21: 255-385.
- Robin J-P and Denis V. 1999. Squid stock fluctuations and water temperature: temporal analysis of English Channel Loliginidae. *Journal of Applied Ecology*, 36: 101-110.

- Roper CFE, Sweeney M and Nauen CE. 1984. FAO Species Catalogue of the World. An annotated and illustrated catalogue of species of interest to fisheries. FAO Fisheries Synopsis, 125(3): 277pp.
- Royer J, Peries P, and Robin J-P. 2002. Stock assessments of English Channel Loliginid squid: updated depletion methods and new analytical methods. ICES Journal of Marine Science, 59: 445-457.
- Salthaug A and Godø OR. 2001. Standardization of commercial CPUE. Fisheries Research, 49: 271-281.
- Segawa S, Isuka T, Tamashiro TS and Okutani T. 1993. A note on mating and egg deposition by *Sepioteuthis lessoniana* in Ishigaki Island, Okinawa, southwestern Japan. Venus, Japanese Journal of Malacology, 52: 101-108.
- Segawa S. 1987. Life history of the oval squid *Sepioteuthis lessoniana* in Kominato and adjacent waters of central Honshu, Japan. Journal of the Tokyo University of Fisheries, 74: 67-105.
- Silas EG, Sarvesan R, Nair KP, Srinath M and Rao KS. 1986. Stock assessment of squids and cuttlefish at selected centers. Bulletin. Central Marine Fisheries Research Institute, 37: 71-79.
- Sivashanthini K, Charles GA and Thulasitha WS. 2009. Length-weight and growth pattern *Sepioteuthis lessoniana* Lesson 1830 (Cephalopoda: Theutida) from the Jaffna Lagoon, Sri Lanka. Journal of Biological Science, 9(4): 357-361.
- Villegas P. 2001. Growth, life cycle and fisheries biology of *Loligo gahi* (d'Orbigny, 1835) off the Peruvian coast. Fisheries Research, 54: 123-31.
- Voss GL. 1963. Cephalopods of the Philippine Islands. Bulletin of the United States National Museum, 234: 180 pp.
- Wada T, Takegaki T, Mori T and Natsukari Y. 2005. Alternative male mating behaviors dependent on relative body size in captive oval squid *Sepioteuthis lessoniana*. Zoological Science, 22: 645-651.
- Young IAG, Pierce GJ, Dali HI, Santos MB, Key LN and Bailey N. 2004. Application of depletion methods to estimate stock size in the squid *Loligo forbesi* in Scottish waters (UK). Fisheries Research, 69: 211-227.

ARTICLE INFO

Received: 12 February 2018

Revised: 09 November 2018

Accepted: 19 November 2018

Available online: 26 November 2018

***Elysia leucolegnote* (Opisthobranchia: Sacoglossa) Jensen 1990, a new record for the Verde Island Passage, Philippines**

Katherine P. Sanchez-Escalona

Mindoro State College of Agriculture and Technology

Main Campus

Victoria, Oriental Mindoro

Correspondence: nyctarinia@yahoo.com

<https://doi.org/10.69721/TPS.J.2019.11.1.04>

ABSTRACT

Aggregations of *Elysia leucolegnote* were observed from Silonay Mangrove and Ecopark, Calapan, Oriental Mindoro, occurring on mudholes with water retained from retreating tide waters. The individuals in the aggregations has white markings on the parapodia and the rhinophores, and yellow marking on each quadrant of the body. This is the first report of the occurrence of the mangrove-associated species from the Philippines which increased the number of *Elysia* species records to 10 species.

Keywords: biodiversity, biogeography, Molluska, new records

INTRODUCTION

Sacoglossans are cryptic slugs, characterized by having no jaw and with longitudinal row of teeth (Swennen 2011) used for piercing algal cells which they feed on (Jensen 2015). Elyssidae, the largest family of the order with over 300 valid species identified to date (Jensen 2007), is closely associated with seaweeds and other marine plants either using these as a substrate or food material (Händeler and Wagele 2007; Jensen 2007; Swennen 1997). The group is known to sequester algal chloroplast and retain them for their photosynthetic functions in a process called kleptoplasty (Rudman 2006).

Elysia, the most speciose genus is characterized by a wing-like parapodia that spreads out giving them a leaf-like appearance. The reef dwelling *Elysia* had been discovered over a hundred years ago, but mangrove-associated species are recent discovery. *Elysia leucolegnote* was identified by Jensen from Hong Kong in 1990. Swennen, on the other hand first described *Elysia bangtawensis* and *E. siamensis* in 1997, and *E. singaporensis* and *E. bengalensis* in 2011.

Jensen (2007) conjectured that the Indo-Malayan and Central Pacific sub provinces as the center of origin and evolution of new Sacoglossan species by having twice the number of species occurring in tropical Australia and West

Indian Ocean. The biogeographic province also has more than twice the number of species in South Pacific and Ryuku Islands. This makes the biogeographic area of Malaysia, Indonesia and the Philippines the most probable center of species diversity for Sacoglossan.

Despite the biogeographic probability, no mangrove-dwelling *Elysia* had been described from the Philippines. This paper provided some notes on *E. leucolegnote* from the Silonay Mangrove Ecopark in Silonay, Calapan, Oriental Mindoro province, a protected area within the Verde Island Passage, the biogeographically recognized center of marine shorefish diversity (Carpenter and Springer 2005).

METHODS

Surveys of the mollusk population was done in Mahal na Pangalan, Calapan ($13^{\circ}25.980'N$ and $121^{\circ}11.503'E$), Silonay, Calapan ($N13^{\circ}24.114'E121^{\circ}13.507'$) and Estrella, Naujan ($13^{\circ}44.569'N$ and $121^{\circ}22.783'E$) (Figure 1). These mangrove areas form a continuous coastal ecosystem on the northeastern coast of Oriental Mindoro.



Figure 1. Study sites of mangrove-associated mollusk survey. *Elysia leucolegnote* was noted only from Silonay but not on two other sites.

The species was found serendipitously at Silonay Mangrove Ecopark, Silonay, Calapan. They appear like seagrass leaves which perfectly camouflage them on the flooded mangrove floor. *Elysia leucolegnote* was found in several aggregations of more than 20 to over a hundred individuals within puddles

from October to December 2016. Holes dug by mudcrabs are often occupied as they retain water from incoming tide.

Photos of individuals as well as of aggregations were taken. Initial identity of the slugs was established from the photos provided by Swennen (2011) who also confirmed the identity of the species.

RESULTS

Aggregations of *E. leucolegnote* were noted in Silonay Mangrove Ecopark during the mangrove-associated mollusks survey in Mindoro, Philippines. The species measured about 3-3.5cm, was characterized by distinctive white markings around the parapodia and on its rhinophores. The green coloration on the parapodia appears mottled. The specimens found here possess four yellow dots, one of each quadrant near the margin of the parapodia (Figure 2). The dots are also visible on the underside. All individuals observed have white spots on the dorsal side of the parapodia but prominence varied among individuals.



Figure 2. *Elysia leucolegnote* from Silonay Mangrove Ecopark with white margin on the parapodia, white rhinophores, and a yellow dot on each quadrant of the body.



Figure 3. A dense aggregation of *Elysia leucolegnote* in a mudhole in Silonay Mangrove Ecopark.

There is no recorded predator yet of the species. Crabs, however, were observed to be picking on individuals within aggregations (Figure 4).

DISCUSSION

Elysia leucolegnote was first identified from Lantau Island, Hong Kong by Jensen in 1990 (Rudman 2003). Swennen (1997) later documented the same species from Thailand together with two other new *Elysia* species. This is the first time that the species is reported from the Philippines.

Extent of occurrence of *Elysia* is currently unknown although it is highly likely that Indo-Malayan region is a hotspot for diversity (Carmona et al. 2011; Jensen 2007). To date, there are nine *Elysia* species documented from the Philippines (GBIF 2018). Documentation of *E. leucolegnote* from the Philippines increased the range of occurrence of the species which were previously documented only from Hong Kong, Singapore, Thailand, and India (Swennen 2011). The documentation of the species from the Philippines,

specifically within the Verde Island Passage is ecologically significant in the biogeography of the group by lending support to Jensen's conjecture that Malaysia-Indonesia-Philippines may be the center of species diversity, being the central point between Japan and Australia where habitat complexity provided for by the archipelagic islands could trap dispersing species and retain them in the area.



Figure 4. Juvenile mudcrabs pick on individual *Elysia leucolegnote* in a mudhole.

Exploration of neighboring mangrove area, particularly from Mahal na Pangalan, Calapan ($13^{\circ}25.980'$ N and $121^{\circ}11.503'$ E) and Estrella, Naujan ($13^{\circ}44.569'$ N and $121^{\circ}22.783'$ E) failed to locate any aggregations indicating that local distribution of the species may be patchy on the scale of tens of

kilometers. As an algal-eating species (Händeler and Wagele 2007), species distribution may follow distribution of their food materials. Crypsis, as well as the dynamic nature of the mangrove forest floor may also contribute to the difficulty in finding the species.

Surveys done in October until November documented the species. Further surveys done in December, however, showed absence of the species. Tides usually inundate the mangrove forest floor in different degrees throughout the year where holes are filled with water. Temporal occurrence of the species thus may be affected by the degree of inundation of sites where holes may serve as retreat sites from desiccation. The variability of tidal inundation throughout the year may also affect growth of their food materials.

Elysia leucolegnote is the fifth *Elysia* species that is documented within the Verde Island Passage, and the only mangrove-associated species so far, underscores the need for more exploration within the area.

ACKNOWLEDGEMENTS

Acknowledgement is extended to BS Environmental Science Class 2017 for their participation in the survey. Also to Dr. Cornelis Swennen who helped confirmed the identity of the species and pointed that it is the first report from the Philippines. Much appreciation is also extended to two anonymous reviewers who contributed to the improvement of the manuscript.

REFERENCES

- Carmona L, Malaquias MAE, Gosliner TM, Pola Mand Cervera JL. 2011. Amphi-Atlantic distributions and cryptic species in Sacoglossan sea slugs. *Journal of Molluscan Studies*, 77(4): 401–412.
- Carpenter KE and Springer VG. 2005. The center of the center of marine shorefish biodiversity: the Philippine Islands. *Environmental Biology of Fishes*, 72: 467-480. DOI: 10.1007/s10641-004-3154-4.
- GBIF (Global Biodiversity Information Facility). 2018. GBIF Occurrence. DOI: 10.15468/dl.s7a3pm. Downloaded on 02 February 2018.
- Händeler K and Wagele H. 2007. Preliminary study on molecular phylogeny of Sacoglossa and a compilation of their food organisms. *Bonner Zoologische Beiträge*, 3: 231–254.
- Jensen KR. 2007. Biogeography of the Sacoglossa (Mollusca, Opisthobranchia). *Bonner Zoologische Beiträge*, 55(1): 255–281.
- Jensen KR. 2015. Sacoglossa (Mollusca: Gastropoda: Heterobranchia) from Northern Coasts of Singapore. *Raffles Bulletin of Zoology Supplement*, 31: 226-249.

- Rudman WB. 2003. *Elysia leucolegnote* Jensen, 1990. [In] Sea Slug Forum. Australian Museum, Sydney. www.seaslugforum.net/factsheet/elysleuc. Downloaded on 02 February 2018.
- Rudman WB. 2006. *Elysia clarki* Pierce, Curtis, Massey, Bass, Karl and Finney, 2006. In: Sea Slug Forum. Australian Museum, Sydney. www.seaslugforum.net/factsheet/elysclar. Downloaded on 02 February 2018.
- Swennen CK. 1997. Two New Gastropods, *Elysia bangtawaensis* and *E. siamensis* from Southern Thailand (Opisthobranchia, Sacoglossa, Elysiidae). Bulletin Zoologisch Museum, 16(6): 33–39.
- Swennen CK. 2011. Large Mangrove-Dwelling *Elysia* species in Asia, (Gastropoda: Opisthobranchia: Sacoglossa). The Raffles Bulletin of Zoology, 59(1): 29–37.

ARTICLE INFO

Received: 05 February, 2018

Revised: 09 January 2019

Accepted: 12 January 2019

Available online: 23 February 2019

Perspectives on outcome-based education among faculty members teaching business courses at a Philippine university

Teresita F. Pepito

College of Business and Management,
Central Mindanao University, Musuan, Maramag, Bukidnon, Philippines

Correspondence: tfpepito.cmu@gmail.com
<https://doi.org/10.69721/TPS.J.2019.11.1.05>

ABSTRACT

The implementation of outcome-based education (OBE) is often controversial especially among faculty members who are tasked with implementing the requisite changes that come with the new system. The study aimed to describe the knowledge, attitudes, and perspectives of faculty members teaching undergraduate Accountancy, Office Administration, and Business Administration courses at a state university in the Philippines regarding OBE. A descriptive qualitative study design was used. A focus group discussion was conducted with all faculty members with at least one-year experience teaching undergraduate accountancy- or management-related courses at a state university in the Philippines. From the FGD, an anonymized transcript was generated, which was analyzed thematically. Most faculty members satisfactorily defined what OBE is. However, when asked what their role is in an OBE learning environment, they were not able to provide conclusive answers. They think that OBE is a necessary upgrade to the traditional system, and is needed to keep education competitive in the face of ASEAN integration. Most participants claimed that they are ready to embrace OBE, but a few expressed reservations towards it. Furthermore, they suggested various improvements for the faculty, the learning infrastructure, and ways to ensure that OBE is implemented well. These findings underscore the need for trainings and dissemination of best practices for OBE implementation, as well as systemic changes in the college to which the faculty members belong to ensure optimal implementation of OBE.

Keywords: Accountancy Education; Business Administration Education; Office Administration Education; Outcome-based Education

INTRODUCTION

Owing to globalization and paradigm shifts in higher education, the Philippines is transitioning from traditional, input-based education to outcome-based education (OBE) (CHED 2012; Llanes 2014). In the traditional system, the focus is mostly on educational input and improving quality of instruction without much regard for any learning outcome. Furthermore, this system is teacher-centered and controlled (CHED 2014). On the contrary, OBE necessitates that the outcomes, or what the learning program intends for

its students to learn or do at its end, is defined first. Once these outcomes are defined, the curricula or syllabus, the pedagogical methods and instruction, and even the methods of assessment are tailored specifically to ensure that the outcomes or goals of the learning program are achieved (Harden 2009). As compared to the traditional system, OBE is learner-centered and learner-controlled (CHED 2014).

In other countries, the implementation of OBE has seen mixed results. Its application on the basic education systems in some areas of the United States, Australia, and South Africa have been perceived as failures, where it was rescinded shortly after its implementation (Donnelly 2007; Lui and Shum 2012). In Australia, the implementation of OBE was seen as one of the reasons for the resignation of secondary school teachers. These teachers thought that OBE was detrimental to education (Fetherston and Lummis 2012). In addition to these, OBE is perceived to set unreasonable learning outcomes and place extra burden on limited school resources and workload of education staff (Donnelly 2007; Lui and Shum 2012). In contrast, its implementation in higher education is more successful, especially in the fields of medicine (Harden 2009), veterinary medicine (Davis 2015), information technology (Lansari et al. 2007), and even in managerial accounting (Lui and Shum 2012).

In the Philippines, there are some studies that document the implementation of OBE and their initial effects. Some studies discussed the experiences of entire higher education institutions (HEI) (Llanes 2014; De Guzman et al. 2017), while some studies focused on the application of OBE to specific subjects such as engineering (Borsoto et al. 2014; Laguador and Dotong 2014), health education (Sana et al. 2015), and industrial psychology (Espiritu and Budhrani 2015). A common finding in these studies is a positive initial experience with OBE, though problems, such as the lack of knowledge of the nuances of its operations, remain.

The contemporary focus on OBE research in the Philippines is due to its recent institutionalization in Philippine higher education (CHED 2014). Despite this, none among the prior studies or government reports show statistics on how many HEIs or programs have actually adopted and implemented OBE, not to mention the extent of its implementation. Furthermore, it is also notable that despite its institutionalization, qualitative studies that explore the depth of perspectives and/or attitudes of faculty members teaching undergraduate business- and management-related courses in Philippine state universities are lacking.

Given the institutionalization of OBE in Philippine HEIs, and the controversy surrounding its implementation on other settings, it is necessary to know the sentiments and perceptions of its main implementers (i.e., the faculty members) so as to address any problem and ensure the success of its implementation. Addressing the dearth of research for this population group

and particular field of study, this exploratory and descriptive study aimed to document and explore in-depth the sentiments and perceptions of these individuals regarding OBE. Specifically, the study aimed to: (1) describe their knowledge and perceptions of OBE; (2) explore their perceived roles in OBE; (3) identify the changes they are implementing to ensure optimal implementation of OBE; (4) characterize their readiness in implementing OBE; and (5) solicit suggestions to ensure optimal implementation of OBE.

METHODS

Research Design

The study is a descriptive, qualitative study which aimed to explore and document the knowledge, attitudes, and perceptions of faculty members of a constituent college of a state university in the Philippines regarding the implementation of OBE for undergraduate business and management courses. A qualitative study permits researchers to understand the feelings, sentiments, perceptions, and perspectives of individuals (Austin and Sutton 2014), and is therefore the most appropriate method to answer the research question of the study. All academic personnel (e.g. instructors, assistant professors, associate professors and professors) who have at least one-year experience in teaching undergraduate courses in Accountancy, Business Administration, and Office Administration in a constituent college of a state university of the Philippines were invited to participate in the study.

Data Collection

A topic guide was prepared by the author to discuss the following: (1) knowledge about OBE; (2) role of faculty members in OBE; (3) their perceptions on the implementation of OBE, specifically elaborating on the question of whether it is a necessary upgrade to the current Philippine higher education system, or an unnecessary disruption to the status quo; (4) changes they intend to do in their respective departments and courses in line with the implementation of OBE; (5) their perceived readiness and the readiness of their respective departments for the implementation of OBE; and (6) their suggestions to improve their personal readiness and their department's readiness for OBE. This topic guide was used in the focus group discussion (FGD) for the study.

The FGD for the study was conducted on June 2015. All faculty members (n=9) participating in the study were given a chance to discuss each of the topics that were listed on the guide. The proceedings of the FGD was tape-recorded. From this record, a transcript of the proceedings of this FGD was generated. To maintain the anonymity of responses, personal identifiers were removed.

Data Analysis

The anonymized transcript was analyzed thematically. *A priori* themes used in the analysis correspond to the topics structured in the topic guide: (1) knowledge about OBE; (2) role of faculty members in OBE; (3) their perceptions on the implementation of OBE; (4) changes they intend to do in their respective departments and courses in line with the implementation of OBE; (5) their perceived readiness and the readiness of their respective departments for the implementation of OBE; and (6) their suggestions to improve the personal readiness and their department's readiness for OBE. Where appropriate, *a posteriori* themes and sub-themes were formulated and categorized from the results of the FGD. Coding of vignettes according to the nodes was carried out by the author and a research associate. All analysis was carried out in NVivo 10 (NVivo 2015).

RESULTS

Description of Study Participants

There were nine participants in the FGD; five of them were instructors, two were assistant professors, and two were associate professors. The youngest respondent was 23 years old while the oldest was 53 years old. Three of the participants are male while the rest are female. Three respondents handled courses in Office Administration, two handled courses in Business Administration while four handled courses on Accountancy.

Introduction to the FGD Findings

Vignettes of this FGD were presented according to the *a priori* themes listed earlier, starting with the knowledge of the respondents regarding OBE, followed by their perceived roles in the OBE learning environment, their attitudes towards OBE, and the changes they deemed necessary for the implementation of OBE. This is followed by a discussion of the preparedness of the respondents for the implementation of OBE at the personal and at the departmental level. Lastly, their suggestions to improve their personal readiness and their respective department's preparedness in implementing OBE was also explored.

There were no new themes arising from the FGDs, and these *a priori* themes were listed as subsequent first-level headers in this section. However, three *a posteriori* subthemes emerged from the FGD: (1) Suggestions to improve the readiness of faculty members in implementing OBE; (2) Suggestions to improve other aspects of learning, and (3) Suggestions to ensure optimal implementation. These subthemes were categorized under the theme *Suggestions to improve readiness in implementing OBE*.

Knowledge about OBE

Most of the faculty members sufficiently defined OBE according to its usual definition. Other definitions of OBE given by faculty members are listed below:

“A multi-disciplinary, student-centered, holistic educational paradigm focusing on skills development and character formation towards producing world-class graduates”

“A system of education... that requires the students to actually demonstrate desired learning outcomes.”

“...focusing on how the student can achieve the desired learning outcome and not just ‘passing’ or ‘failing’ a given exam”.

“...acknowledgment that each student has his/her unique learning style and the teacher’s role is to see that uniqueness, respect it, and use it to achieve the outcome.”

Role of Faculty Members in OBE

As compared to when the faculty members were asked about their knowledge on OBE, in which most respondents answered, only a few faculty members elaborated on their perceived role in an OBE learning environment:

“...engagement of students in activities that lead them to embody the outcomes set by the teacher”

“As teachers, we should (be) focusing on (developing) values, attitudes, skills and readiness of the students to make them ready in their respective practices of profession.”

Regarding this role, they were asked what general outcomes are expected of them as they embrace outcome-based education. When asked how they would want their students to be as they finish their education:

“We aim to produce well-rounded graduates by allowing them to learn, not just didactically but through performing in class and producing output.”

Perceptions on the Implementation of OBE

When asked if OBE is a necessary upgrade to the current Philippine higher education system, or an unnecessary disruption to the status quo, all respondents concurred that it is a much-needed upgrade to the traditional didactics used by the Philippine higher education system. In discussing their perceptions, they benchmarked the traditional system against what is used and recommended by the Association of Southeast Asian Nations (ASEAN). Overall, they perceived that the traditional system does not produce globally-competitive graduates and that the Philippines need to upgrade towards OBE

to be at par, not just with other members of the ASEAN, but also with other countries in the world:

“(OBE) helps students become more competent in their field of concentration, and enhances their skills to be able to compete with (the graduates of) other ASEAN countries. The current educational system of the Philippines produces graduates that are far behind that of other ASEAN countries; the graduates are intelligent, but not capable of producing tasks or outputs that the workplace needs.”

“This change can help our students develop the necessary competencies as we want them to perform the desired actions/skills.”

“It is mandatory in the ASEAN integration; thus the Philippines should do it. Furthermore, it is necessary that students should possess the necessary skills and competence that they may be ready for life after school; thus HEI’s should focus on the right outcomes in the development of their students.”

While maintaining a general positive attitude towards OBE, one faculty member expressed guarded optimism regarding its implementation and institutionalization:

“In order for us to produce world-class graduates and highly desirable human resource (and to contribute towards a) globally-competitive workforce, OBE should be implemented in the country. But changes should be introduced slowly, not abruptly.”

Another faculty member opined that while attitudes towards OBE are generally positive among them, there is one greater question that takes precedence above all else if they are to make OBE a reality in their college:

“While indeed it is a much-needed change, understanding on our part is necessary, as well as sacrifices. Probably, it is not important whether we have positive or negative attitudes towards OBE; the better question would be whether we are willing to make the necessary sacrifices to make OBE a reality.”

When asked whether the respondents are indeed willing to make the necessary sacrifices to make OBE a reality, they were unequivocal in committing to integrate OBE to their pedagogy.

Changes to be Implemented in Response to OBE

All faculty members said that OBE is not an entirely new concept to them. However, they stressed that changes have to be implemented once OBE is fully institutionalized. Faculty members handling various courses in Accountancy, which is heavily reliant on practical knowledge, asserted that they have incorporated what is currently known as OBE vis-à-vis the traditional system as they deem it necessary for the students to master some competencies at the end of the course:

“OBE is not a new approach to the Accountancy department. Even during the implementation of the teacher-centered approach, we are already incorporating outcome-based approach in accounting where students are required to make an output to every activity such as preparing financial sheets, conducting audits or consultancy engagements.”

Even if OBE is not a new concept for those who teach Accountancy, they agreed that some changes are necessary despite this:

“Somehow, the department (of Accountancy) had been applying part-and-parcel of what is (known as) OBE. We will just need to check and align the individual course outcomes to the national goals so that we can be considered ready for OBE.”

On the other hand, faculty members handling courses in Office Administration have started to work towards aligning their curricular offerings towards competency-based outcomes patterned after the vocational offerings of the Technical Skills Development Authority (TESDA), the government agency mandated in monitoring and providing trainings and technical and vocational skills in the Philippines. They justified that this move is seen to increase the qualifications and hone the skills of its graduates. Furthermore, they opined that from now on, graduates of the Office Administration program are not just expected to have university degrees, but also qualifications based on various competency-based skills relevant to Office Administration.

“The department’s preparation for OBE has been started already. The department carefully constructs its new program curriculum to match the new system; integrating more activities and assessments.”

“The department is currently revising its curricula to align with the competency-based curriculum of TESDA. We are encouraging students to take national assessment examinations in different TESDA programs.”

The respondents who handle Business Administration courses, meanwhile, focused their immediate changes in improving syllabi and methods of delivery:

“Right now, syllabus for each subject has been revised to include activities for a more effective learning experience and to include a clearer set of goals/outcomes that are learner-centered.”

“(We seek to) change (the) syllabi of course offerings. That for every lesson learned by the students, they should know how and when to apply that particular lesson.”

Readiness in Implementing OBE

While majority expressed their personal readiness to implement OBE, some expressed reservations on the matter. With regards to the readiness at the department level, everybody said that they have been integrating OBE, albeit in a piecemeal manner in their everyday teaching.

“My colleagues had been employing OBE techniques in their respective classes. Implementing OBE in all of their classes is not so far-fetched.”

“Before the OBE have been introduced, I do believe that I’m already practicing OBE in my class. I see to it that after completing the course, my students must possess certain skills, qualities and attitudes.”

“Personally, I believe that the department (of Office Administration) is ready for OBE implementation. In fact, our students have already started and are able to have a National Certification in Front Office (from TESDA). And we are looking forward for another kind of national certificate in the coming semester.”

Summarizing the need for readiness and the readiness of almost all respondents, one faculty member opined:

“We are ready and we should be ready to be in-line with the ASEAN integration. We would also like our students to be ready for ASEAN integration.”

Suggestions to Improve Readiness in Implementing OBE

While most respondents claimed that they are ready for OBE, they still had suggestions on how to ensure seamless transition to the full-fledged adoption of the OBE paradigm. They opined that these suggestions are necessary to ensure that the implementation of OBE will bring out the best

for both the faculty, the college, and the students. These suggestions were categorized into three subthemes: (1) *Suggestions to improve readiness of faculty members*; (2) *Suggestions to improve other aspects of learning*; and (3) *Suggestions to ensure that OBE is implemented well*.

Suggestions to improve the readiness of faculty members in implementing OBE. To improve the readiness of faculty members in implementing OBE, they suggested more avenues for professional development (e.g. in the form of trainings or postgraduate scholarships). Furthermore, they emphasized that the CHED, the Philippines' regulatory agency for tertiary education, should provide more trainings and provide more avenues for sharing best practices:

“I suggest for more OBE-related trainings, especially for methods of delivery and assessment, for the faculty.”

“I think that the CHED should play a more active role in implementing OBE through trainings, providing universities with best practices and experiences of other institutions that have successfully integrated OBE...”

In addition to the increased involvement of CHED and trainings, a respondent also brought up how academic freedom should be maintained in the era of OBE:

“The academic freedom of the faculty is to be maintained and respected; learning in business cannot be restricted to the four walls of the classroom. The students should be afforded all the opportunities they could to learn about their field of interest in the form of immersions, community involvement and other forms of informal learning.”

Suggestions to improve other aspects of learning. Some faculty members argued that for the transition to OBE to be successful, it is not only them that need to change in preparation for the full-scale implementation of OBE. In particular, they suggested improvements to the current learning infrastructure, overall curriculum, and method of delivery:

“Improve the On-the-Job Training (i.e. practicum) program, not just towards local industry partners, but the college should work into establishing ties with international industry partners. We as a college, should also emphasize practice-oriented teaching.”

“Acquire more up-to-date technology, buy more computers and improve laboratories. More major offerings should be placed to accommodate the dynamic business landscape. Large classes should be reduced as it hampers with the

teaching-learning environment. Both the student and teacher should be comfortable in their learning environment. The faculty should also keep himself/herself abreast with new information in the dynamic business field”

“The faculty of the college should be able to design instructional materials that is in-line with OBE.”

Suggestions to ensure optimal implementation. In addition to improvements among the faculty and other aspects of learning, some faculty members suggested that there should be a means to ensure that OBE is implemented well and quality assurance standards are met.

“...and providing forms of assessment frameworks so that the college will have an objective guide in implementing OBE.”

“We should be able to have ourselves assessed whether what we are doing in the OBE is right or wrong. We should contact accreditation agencies and align ourselves to global standards.”

DISCUSSION

The study aimed to describe the perspectives of faculty members teaching Accountancy, Office Administration, and Business Administration courses at a state university in the Philippines regarding OBE. Most faculty members satisfactorily defined what OBE is. However, when asked what their role is in an OBE learning environment, they were not able to provide conclusive answers. They think that OBE is a necessary upgrade to the traditional system, and is needed to keep the college competitive in the face of ASEAN integration. Most participants claimed that they are ready to embrace OBE, but a few expressed reservations towards it. Furthermore, they suggested various improvements for the faculty, the learning infrastructure, and ways to ensure that OBE is implemented well.

CHED formally defines OBE as “an approach that focuses and organizes the educational system around what is essential for all learners to know, value, and be able to do to achieve the desired level of competence” (CHED 2014). Considering that almost all respondents gave a definition similar to this, it can be said that the respondents can define OBE well. However, some participants gave responses which may be different as to how CHED defines OBE. As such, it should be clear to everyone, especially to faculty members implementing it, what OBE is, and what OBE is not.

When the respondents were asked to discuss the definition of OBE, they were noticeably quiet, save for the definitions they discussed earlier. The

role of faculty in OBE as “designers of learning methods and environments, developers of competencies and talents of students, producers of student learning and success, empowering learners, and promoters of shared governance, teamwork and individuality” and as “facilitator of learning” (CHED 2014). While some participants gave satisfactory answers, their relative silence may indicate a knowledge gap on the practical aspects of OBE. This finding is similar to the findings of other local studies, which posit that while knowledge of OBE among faculty members are excellent, knowledge about their specific roles may be lacking (De Guzman et al. 2017). These underscores the need for the dissemination of more information, with the role of faculty members in OBE as a starting point.

At the time of the study, HEIs around the country were rife with discussions on the implications of the ASEAN Economic Community, which was formally established six months (The ASEAN Secretariat 2017) after the FGD was conducted. The respondents thought that Philippine HEIs are losing their edge in producing globally-competitive graduates and need to be reformed if it were to produce graduates that will be competitive even in the face of ASEAN integration. These concerns were not misplaced; even Philippine education experts remark that there is a pressing need to (1) increase the relevance and quality of education for Filipinos and (2) increase the competitiveness of Philippine HEIs in the global scale (Bautista 2016).

The specific changes being or had been implemented in preparation for OBE that has been documented in this study are positive signs that the institution is implementing changes to be in-line with OBE. CHED introduced OBE in 2014 to ensure the competitiveness of Philippine HEIs and their graduates (CHED 2014). These reforms are in-line with the establishment of the ASEAN Economic Community, which may necessitate changes in the educational systems in the region to maintain the global competitiveness of individuals in a dynamic labor market. These improvements may include, but are not limited to, changes in national educational paradigms, methods of pedagogy, delivery and assessment, as well as level of governmental support to education (McCarthy 2013). However, the implementation of these changes begs an evaluation as to whether or not these changes have really led to an increase in the competitiveness of the institution or its graduates.

While most study participants expressed eagerness for OBE, some have expressed reservations. These misgivings may have stemmed from the simultaneous introduction of OBE and other educational reforms (i.e., K-to-12) in the country (Bautista 2016). This may have led some respondents to perceive that changes are being done hastily without particular regard to whether these reforms are actually being implemented well. These sentiments imply that there may be a need for appropriate scaling and/or timing of the implementation of reforms so as to ensure the success and sustainability of its implementation.

In a recent memorandum, CHED continues to guarantee the academic freedom of universities and colleges. However, there are notable exceptions such as: “maintaining minimum unit requirements for specific academic programs, general education distribution requirements as determined by CHED, and specific professional subjects as may be stipulated by the various licensing entities” (CHED 2011). The raising of this concern by a faculty member further emphasizes the need for dissemination of information, this time, pertaining to academic freedom and its limits in the context of OBE.

Other aspects of learning that ought to be improved include classrooms and class sizes, computers and other learning infrastructure, faculty development, and building of institutional linkages, both local and international. The rationale behind these suggestions is that OBE implementation might be below par if fundamental deficiencies in the current system are not addressed. Classes in the college are often large where there may be more than 40 students in a class. While there is no specific figure that can be considered as an optimal student-to-faculty ratio, in general, smaller classes are better as students receive more attention from the teacher and there are more interactions between students and teachers (Blatchford et al. 2011). Decreasing class size implies that the college should build more classrooms, buy new computers and other equipment, and hire more faculty members. Similar recommendations are also given by another local study, which suggests pedagogical changes and investments to infrastructure to ensure optimal implementation of OBE (Custodio et al. 2017).

Regarding faculty development, faculty members are encouraged to apply to the various scholarships being offered to faculty members of various HEIs, especially the K-to-12 transition program (Higher Education Development Center 2016). Building of institutional linkages were suggested to provide more options for students in their practicum, which will give them the option to hone their skills in top business and management firms locally and internationally. The responsibility of fostering institutional linkages ultimately falls under the purview of the college and university management. However, alumni can play a vital role in building this, especially if they are working with the companies with which their alma mater is hoping to build institutional linkages with.

While there may be no definite frameworks yet to monitor and evaluate OBE implementation as of the time of the FGD, this perception of the study participants should be corrected. Currently, there is now a validated assessment framework used for the accreditation of HEIs in line with OBE (De Lara 2017). Nevertheless, this only highlights the need for the dissemination of information especially in the practical and implementation aspects of OBE.

The greatest caveat in interpreting the findings of this study is the tendency of the respondents to give more favorable responses while being studied or observed (Oswald et al. 2014). Termed Hawthorne effect, this bias often plagues studies which rely substantially on subjective and/or observational data. While the author of the study did her best to guarantee the anonymity of the respondents and their immunity from any responsibility that may arise from the things they discussed in the study, there might still be Hawthorne effect despite these efforts. Another important limitation that should be considered in interpreting the results of the study is that there was no opportunity to triangulate these findings with data collected through other means. The nature of the data collected (e.g. personal sentiments, etc.) precludes any form of triangulation; hence, it was not performed. Furthermore, the highly-specific study population may prevent generalization of its findings to other contexts. Nevertheless, its findings may be useful in the development of other research hypotheses concerning the implementation of OBE.

The most salient recommendations of the study focused on trainings and/or disseminations of best practices and information regarding OBE. These trainings and/or dissemination activities should include but are not limited to: (1) explaining what OBE is, and what OBE is not; (2) the role of faculty in OBE, including the limits of their academic freedom; and (3) new assessment frameworks for OBE. Prior to any training, a needs assessment may be carried out to determine which aspects of OBE should to be tackled in-depth. Furthermore, considering that some faculty members raised the concern that reforms may have been introduced too quickly, there may be a need for government agencies tasked to implement education reforms to see if these changes are actually implemented well and to scale its implementation accordingly if needed. Other changes in the learning environment and infrastructures were also suggested to ensure optimal implementation of OBE.

Further research may focus on the assessment of knowledge, attitudes, perceptions, behaviors and preparedness of faculty members across several HEIs and disciplines to determine the extent of information dissemination that the CHED should undertake. An ever better recommendation would be conducting studies utilizing both qualitative and quantitative data. This will allow triangulation of qualitative data as well as enrich the findings of quantitative studies. Ultimately, there ought to be a monitoring of the implementation of OBE across all HEIs and degree programs to ensure that it is being implemented well. The evaluation of OBE implementation should know whether or not it helped higher education in the country to become more relevant to local and international needs, and whether or not it had really increased the competitiveness of Philippine HEIs and their graduates in the face of ASEAN integration. Considering that these two are the main reasons for OBE's implementation across the country, it is against these objectives that

the success of the OBE and its institutionalization in Philippine HEIs should be measured against.

ACKNOWLEDGEMENTS

The author would like to express her gratitude to the University of the Philippines System, the Commission on Higher Education, the Temasek Foundation, and the Center for Development of Teaching and Learning of the National University of Singapore for the training and support given in the conduct of this research. The author would also like to thank the administration and non-academic staff of the participating state university for their permission and support in the conduct of the study. Lastly, the author would like to express her appreciation to the two anonymous reviewers who have provided insightful comments for the improvement of this manuscript.

REFERENCES

- Austin Z and Sutton J. 2014. Qualitative research: getting started. *The Canadian Journal of Hospital Pharmacy*, 67(6): 436-440.
- Bautista MCR. 2016. K to 12 and the higher education reform agenda. Presented at the National Research Council of the Philippines Policy Forum.
<http://www.nrcp.dost.gov.ph/presentations?download=166:dr-bautista-kt012-reform-agenda>. Accessed on 3 March 2018.
- Blatchford P, Bassett P and Brown P. 2011. Examining the effect of class size on classroom engagement and teacher-pupil interaction: differences in relation to pupil prior attainment and primary vs. secondary schools. *Learning and Instruction*, (21): 715–730.
- Borsoto L, Lescano J, Maquimot N, Santorce MJ, Simbulan A and Pagcaliwagan A. 2014. Status of implementation and usefulness of outcomes-based education in the Engineering Department of an Asian University. *International Journal of Multidisciplinary Academic Research*, 2(4): 14–25.
- CHED (Commission on Higher Education). 2011. Revised guidelines in the formulation of CHED policies, standards, and guidelines of academic programs amending CHED Special Order No. 42 Series of 2003 otherwise known as “Guidelines for the formulation of policies and standards of academic programs.” <http://ched.gov.ph/cmo-2-s-2011/>. Accessed on 3 March 2018.
- CHED (Commission on Higher Education). 2012. Policy standard to enhance quality assurance (QA) in Philippine Higher Education through an outcomes-based and typology-based QA. <http://ched.gov.ph/cmo-46-s-2012/>. Accessed on 3 March 2018.

- CHED (Commission on Higher Education). 2014. Handbook on Typology, Outcomes-Based Education and Institutional Sustainability Assessment. <http://www.ched.gov.ph/wpcontent/uploads/2014/06/Handbook%20on%20Typology%20Outcomes.pdf>. Accessed on 3 March 2018.
- Custodio PC, Espita GN and Siy LC. 2017. The Implementation of Outcome-Based Education: The Case of the University of Perpetual Help System DALTA Las Piñas Campus. Presented at the International Conference 2017. http://www.vnseameo.org/InternationalConference2017/materials/12_PerlitaCustodio_GinaEspita_Lourelisiy_Fullpaper.pdf. Accessed on 6 November 2018.
- Davis MH. 2015. Outcome-based education. *Journal of Veterinary Medical Education*, 30(3): 258-63. DOI: 10.3138/jvme.30.3.258
- De Guzman MFD, Edano DC and Umayan Z. 2017. Understanding the essence of the outcomes-based education and knowledge of its implementation in a technological university in the Philippines. *Asia Pacific Journal of Multidisciplinary Research*, 5(4): 64-71. <http://www.apjmr.com/wp-content/uploads/2017/11/APJMR-2017.5.4.08.pdf>
- De Lara MGO. 2017. Outcome-based program quality assurance accreditation survey instrument: its development and validation. *The Normal Lights*, 11(2): 1-30. <http://po.pnuresearchportal.org/ejournal/index.php/normallights/article/view/525>
- Donnelly K. 2007. Australia's adoption of outcomes-based education - a critique. *Issues in Educational Research*, 17(2): 183-206. <http://www.iier.org.au/iier17/donnelly.html>
- Espiritu JL and Budhrani K. 2015. Implementing an outcome-based education (OBE) framework in the teaching of industrial psychology. Presented at the DLSU Research Congress. http://www.dlsu.edu.ph/conferences/dlsu_research_congress/2015/grc/GRC-I-001.pdf. Accessed on 4 March 2018.
- Fetherston T and Lummis G. 2012. Why western Australian secondary teachers resign. *Australian Journal of Teacher Education*, 37(4): 1-20. DOI: 10.14221/ajte.2012v37n4.1
- Harden RM. 2009. AMEE Guide No. 14: Outcome-based education: Part 1-An introduction to outcome-based education. *Medical Teacher*, 21: 7-14. DOI: 10.1080/01421599979969
- Higher Education Development Center (Philippines). 2016. About the K to 12 Transition. <https://chedk12.wordpress.com/about-kto12/>. Accessed on 4 March 2018.
- Laguador DJM and Dotong DCI. 2014. Knowledge versus practice on the outcomes-based education implementation of the engineering faculty members in LPU. *International Journal of Academic Research in Progressive Education and Development*, 3(1): 63-74. DOI: 10.6007/IJARPED/v3-i1/640

- Lansari A, Tubaishat A and Al-Rawi A. 2007. Using an outcome-based information technology curriculum and an e-learning platform to facilitate student learning. *Issues in Informing Science & Information Technology*, 4: 461-71.
<http://proceedings.informingscience.org/InSITE2007/IISITv4p461-471Lans361.pdf>
- Llanes C. 2014. Adoption of outcomes-based education in the philippines: the TIP experience. Presented at the 2014 ASAIHL Conference, Singapore.
http://conference.ntu.edu.sg/asaihl/Documents/PPTs/Parallel%20Session%20PPT/4_1_1%20Cynthia%20C.%20Llanes.pdf. Accessed on 4 March 2018.
- Lui G and Shum C. 2012. Outcome-based education and student learning in managerial accounting in Hong Kong. *Journal of Case Studies in Accreditation and Assessment*, 2: 1-13
<http://www.aabri.com/manuscripts/10562.pdf>
- McCarthy R. 2013. UNESCO Office in Bangkok: ASEAN integration: let's not forget the implications for education.
<http://www.unescobkk.org/education/news/article/asean-integration-lets-not-forget-the-implications-for-education/>. Accessed on 5 March 2018.
- NVivo. 2015. Version 10. Australia: QSR International.
- Oswald D, Sherratt F and Smith S. 2014. Handling the Hawthorne effect: The challenges surrounding a participant observer. *Review of Social Studies*, 1(1), 53-73.
- Sana EA, Roxas AB and Reyes, ALT. 2015. Introduction of outcome-based education in Philippine health professions education setting. *Philippine Journal of Health Research and Development*, 19(1): 60-74.
- The ASEAN Secretariat. 2017. ASEAN Economic Integration Brief, (1). Retrieved from http://asean.org/storage/2017/06/AEIB_No.01-June-2017_rev.pdf. Accessed on 5 March 2018.

ARTICLE INFO

Received: 14 July 2018

Revised: 07 November 2018

Accepted: 20 February 2019

Available online: 04 March 2019

Development of an improvised convertible distillation apparatus for teaching and learning chemistry

Henley Fontamillas Galiga

Romblon State University

Liwanag, Odiongan, Romblon

Correspondence: hgaliga@yahoo.com

<https://doi.org/10.69721/TPS.J.2019.11.1.06>

ABSTRACT

Distillation is an important concept in chemistry as it involves separation techniques which are widely used in various industries. However, despite its significance, it is hardly understood and appreciated because it is rarely performed in laboratory experiments. Distillation requires expensive apparatus to conduct which most schools cannot afford. Hence, an improvised convertible distillation apparatus for simple, fractional and steam distillation was developed using common household and recyclable materials. Improvised measuring devices were also fabricated to determine the purity of the distillates. The performance of improvised apparatus was assessed and compared with the standard apparatus using real samples. The improvised apparatus, using fractional distillation set-up, produced 91.3% alcohol from alcoholic beverage while the simple/steam distillation setup, yielded distilled water from the salt-water sample and essential oil from pomelo (*Citrus maxima*) peel with percentage yield of 0.56%, respectively. The improvised apparatus for fractional distillation yielded a higher alcohol content ($\bar{x}=91.3\%$; 95%CI=91.0, 91.6) than the standard apparatus ($\bar{x}=85.7\%$; 95%CI=85.3, 86.1) while the efficiency of separation of the improvised apparatus for simple/steam distillation was comparable with standard apparatus. Thus, the improvised apparatus offers a cheaper alternative for conducting distillation process in chemistry experiments. The cost of performing distillation process is further reduced by using improvised measuring devices to measure the purity of the distillates in lieu of chemicals and reagents. Aside from being cost-effective, the improvised apparatus is easy to construct, durable, user-friendly and safe to use.

Keywords: chemistry experiments, distillation, improvisation, low-cost

INTRODUCTION

Laboratory plays an important role in effective teaching and learning chemistry. Concepts in chemistry are better understood and appreciated if practical works are conducted in a well-equipped laboratory. It focuses more on student-centered teaching approach, which is more effective in the mastery of skills and deep understanding of concepts in science than the teacher-centered approach (Granger et al. 2012). In the Philippines, the lack of science equipment and facilities (Marinas undated) has been a serious concern for public school teachers, particularly in rural areas. This occurs as a result of an

inadequate budget to meet the demand for acquiring expensive laboratory materials and equipment (Padolina and Magno undated). Thus, the concept of improvisation became popular in conducting laboratory experiments as it helps address the problem of lack of equipment due to financial constraints and brings out creativity among students and teachers. Improvisation could be defined as the making of alternative instructional materials from the use of locally available resources (Ndirangu 2003) and it is often advocated as a low-cost solution in terms of equipment and chemicals (Kimel 1998). It brings out the same learning results as standard materials.

Several low-cost apparatus for chemistry experiments have been developed from simple laboratory glassware (Yitbarek 2012) to sophisticated laboratory instruments to address the problem of insufficient budget. Muhammad and Lawal (2015) made use of common household materials as an alternative to standard laboratory equipment and reagents. An ordinary syringe was used as vacuum source in vacuum filtration (Zhilin and Kjonaas 2013) and as electronic buret for acid-base titration (Cao et al. 2015). To introduce the concept of spectroscopy to undergraduate chemistry laboratory, Wigton et al. (2011) developed a low-cost portable fluorimeter using a 360 nm light emitting diode (LED) for excitation and a silicon photodiode for detection. LEGO blocks were utilized to make an inexpensive visible light absorption spectrophotometer (Albert et al. 2012) and were also used to construct a simple, inexpensive, and robust colorimeter (Asheim et al. 2014). And recently, a spectrophotometer using a smartphone's light sensor as a detector and an application to calculate and display absorbance values was constructed and tested by Hosker (2018).

While there are growing interests in the fabrication of inexpensive laboratory apparatus for teaching chemistry in the past few years, only a few studies have been dedicated to the development of low-cost distillation apparatus (Babu et al. 2002). Distillation is considered one of the most important separation techniques in chemistry. It is widely used in the production of essential oils (Stratakos and Koidis 2016) and alcohol (Cho et al. 2013) and the extraction of medically important organic compounds in plants (Singh 2016). However, distillation apparatus that are available in the market are very expensive and most parts are usually made of glass which is susceptible to cracks and breakages. Additionally, conventional distillation set up employs open flame as the heat source which constitutes a fire hazard. Literature for improvised distillation apparatus is limited and no studies have been found as to the development of an improvised distillation apparatus that can be used interchangeably for simple, fractional and steam distillation processes. It is, therefore, the aim of the study to develop an improvised distillation apparatus using household and recyclable materials for simple, fractional and steam distillation that is safe to use, cost-effective, durable and easy to assemble. The study also aims to fabricate improvised measuring

devices to test the purity of the distillates instead of using chemicals and reagents.

METHODS

The study was conducted in three stages. The initial stage includes the modification and characterization of an electrothermal cup as heat source and distilling pot. This was followed by the development and optimization of interchangeable distilling lid which allows the use of improvised apparatus for simple, fractional and steam distillation. This stage also includes the fabrication of improvised devices for measuring conductivity and density to determine the purity of the distillates collected from simple and fractional distillation, respectively. The last stage was performance and cost evaluation of the fabricated distillation apparatus. Real samples were used to compare the performance of improvised distillation apparatus with a commercially available standard distillation apparatus. Correlation analysis and paired t-test at 95% confidence interval were used as a statistical tool to compare the efficiency of improvised apparatus with standard apparatus (McDonald 2014; Kim 2015). Statistical values were computed using Analysis Toolpak in Excel.

Modification and Characterization of Improvised Heat Source

Figure 1 is the schematic diagram depicting a complete set-up for improvised distillation apparatus which was basically composed of electrothermal cup, interchangeable cup lid, condenser, light dimmer, digital multimeter, and submersible aquarium pump. A one-liter stainless steel electrothermal cup was used as the heat source and as distilling pot. Bended glass tubing was inserted and fixed on the side of the cup to serve as a water level indicator.

The light dimmer and digital multimeter were integrated into the power plug of the electrothermal cup in a manner shown in Figure 2. The light dimmer was used as the power switch and voltage regulator while the digital multi-meter served as the readout device for voltage monitoring. The heating performance of the modified electrothermal cup was characterized by heating 500 ml of distilled water using different voltages set from 50 to 200 volts with 50-volt increment.

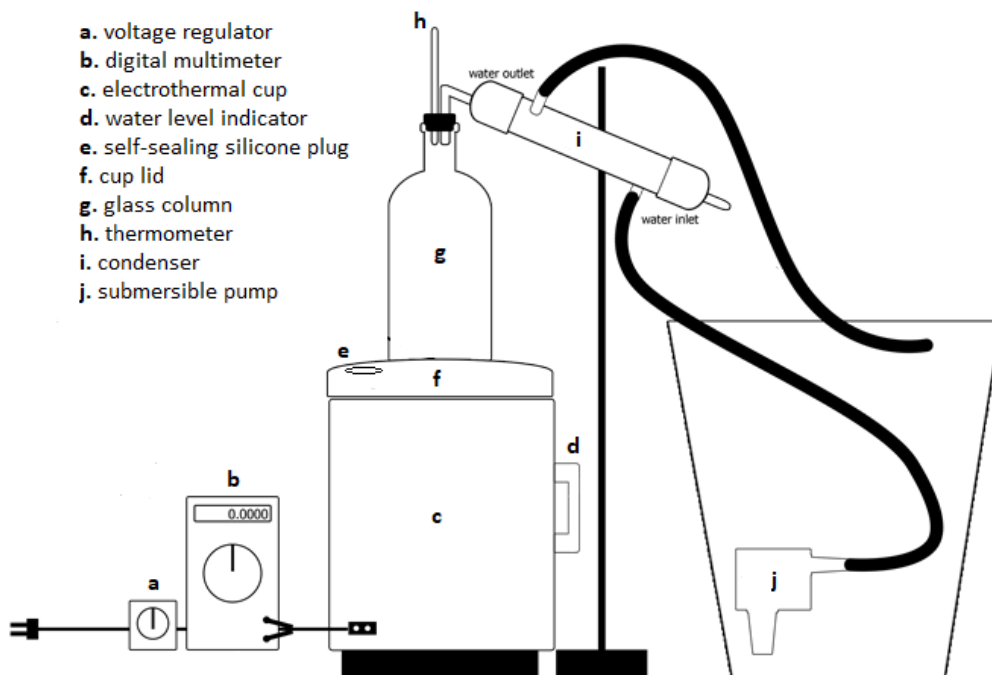

Figure 1. Schematic diagram of improvised distillation set-up

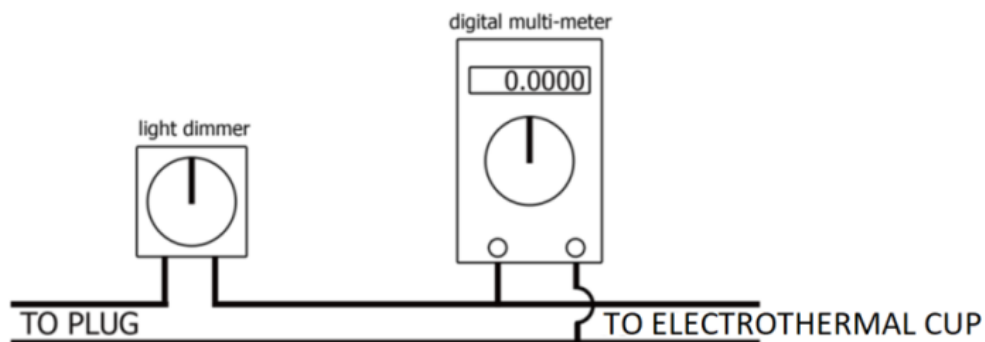

Figure 2. Modified power plug of electrothermal cup equipped with light dimmer and digital multimeter.

Fabrication and Optimization of Measuring Devices and Interchangeable Distilling Lid

Fabrication of improvised measuring device. The circuit for improvised conductivity tester was adapted from Katz and Willis (1994) with some modifications. Copper electrodes were replaced by TRS earphone jack and a 9-volt AC/DC adaptor was provided in addition to the 9-volt battery as

the power source (Figure 3). Electrical components were housed in an empty permanent marker.

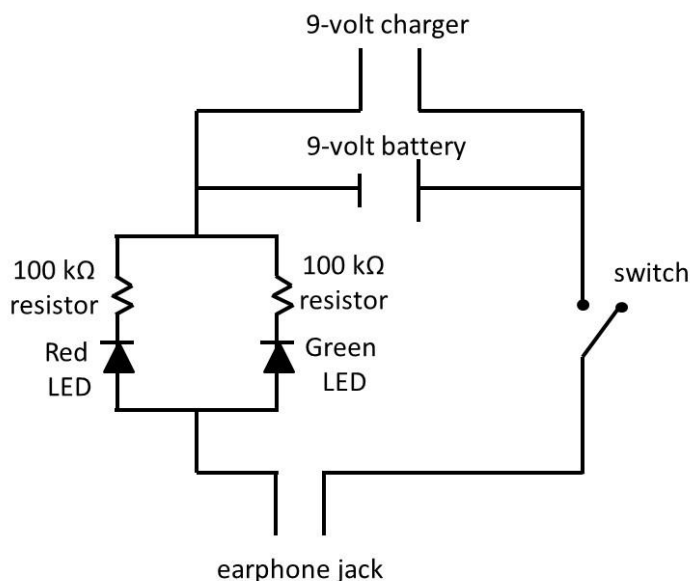

Figure 3. Circuit diagram for modified conductivity meter (top) and fabricated conductivity tester (bottom).

Improvised pycnometer was built from an empty bottle of nail polish and capillary tube (Figure 4). The capillary tube was inserted and fixed to a rubber plug which tightly covers the bottle. The performance of improvised pycnometer was compared against a standard pycnometer using different concentrations of ethanol.



Figure 4. Improvised pycnometer (left) and standard pycnometer (right).

Interchangeable distilling lid. The glass column with an external diameter of 55 mm was made from clear soda bottle which bottom was cut off. An open-end glass column was placed over the pre-cut hole at the center of the cup lid. A 19-cm long glass column was used for simple/steam distillation while a longer glass column filled with column packing was utilized for fractional distillation (Figure 5). A hole with self-sealing silicone plug was provided on the cup lid for simple/steam distillation to facilitates replenishment of vaporized water during steam distillation. Glass column for fractional distillation was constructed from several pre-cut glass bottle joined together by silicone sealant. A stainless steel mesh was placed inside the lower part of the glass column to support column packing. The length of the glass column, as well as the type and size of column packing, for fractional distillation were investigated. Glass marbles and stainless steel sponge were used as column packing.



Figure 5. Electrothermal cup (a) and distilling lid for simple/steam distillation (b) and fractional distillation (c).

The condenser was constructed using one-foot (30.28 cm) long polyvinyl chloride (PVC) pipe (size 1”), PVC caps and 7 mm glass tubing. PVC caps were used to seal both ends of the pipe. A 22-inch (55.88 cm) glass tubing was bent on one end and inserted through the length of the pipe passing both caps. Two pieces of one-inch (2.54 cm) glass tubing were inserted on the side of the pipe opposing each other and proximate to both ends of the pipe to serve as water inlet and outlet. All joints were sealed with two-part epoxy resin to prevent leakages.

Performance Evaluation

Three hundred milliliters of samples were used for simple and fractional distillation while 250 grams of plant sample were utilized for steam distillation. Distilled water and absolute ethanol were used as reference standards throughout the study. Boiling stones were added to the samples to prevent bumping. A submersible aquarium pump was utilized to re-circulate water coming out of the condenser. Ice was added to the water reservoir to provide a continuous supply of cold water to the condenser. All measuring instruments were calibrated prior to use. The improvised apparatus applied for all types of distillation process were run against standard distillation apparatus. The Vigreux column was used as the standard fractionating column. Three trials were conducted for each type of distillation process.

Simple distillation. The performance of the simple distillation set-up was evaluated by separating water from the salt-water mixture. Three hundred milliliters of water samples were placed inside the cup. The voltage was set at 150 volts. The temperature was monitored and recorded at the first drop of the distillate. The purity of distillates was determined by measuring its conductivity using the fabricated conductivity tester and results were compared with the conductivity scale given in Table 1.

Table 1. Degree of electrical conductivity of sample solution based on lighted light emitting diode (LED).

Scale	Red LED	Green LED	Conductivity
0	Off	Off	None
1	On	Off	Medium
2	On	On	High

Fractional distillation. The efficiency of the fractional distillation set-up was determined using 80-proof liquor. The glass column was wrapped with aluminum foil leaving an air space between the column and the foil to serve as an insulator (Lancaster 2017). Three hundred milliliters of the sample were transferred into the cup. The voltage was initially set at 150 volts and adjusted to 100 volts after the temperature reached ten degrees below the boiling point of ethanol (78°C). The voltage was further adjusted upon the first drop of distillate to maintain a drop rate of 20 drops per minute (Yoder et al. undated) while maintaining the temperature close to 78°C. Fractions were collected every 10 ml of distillates in a graduated cylinder placed in an ice bath. The temperature was monitored and recorded for each fraction collected. Distillation process was continued until a sharp increase in temperature was observed and distillation was stopped when the temperature reached the boiling point of water. The percentage composition of ethanol and water in each fraction was determined indirectly by comparing the density of each fraction with the Table for Concentration of Ethanol-Water Mixture Versus Specific Gravity at Various Temperature (Perry et al. 1997). The density was measured using an improvised pycnometer. The performance of improvised apparatus for fractional distillation was compared with standard apparatus for fractional distillation with Vigreux column.

Steam distillation. The efficiency of the improvised steam distillation was evaluated based on the physical properties and percentage yield of oil obtained from the plant sample. Two hundred fifty grams of grated pomelo peel and 400 ml of distilled water were transferred into the electrothermal cup. The water level was marked and monitored through the water level indicator. Glass vessel with distilled water was inserted into the self-sealing silicone plug to replenish the water lost during steam distillation.

Steam distillation was carried out at 100-volt setting and continued until no visible droplet of oil was observed in the distillate.

RESULTS

Performance of Modified Electrothermal Cup as Heat Source

Simple, steam and fractional distillation share basic apparatus consisting of heat source, distillation pot, distilling head, thermometer, condenser, and receiving flask. A fractionating column placed between the distillation pot and condenser differentiates fractional distillation from simple and steam distillation set-up.

A modified electrothermal cup was used as the heat source and distillation pot. The effect of a voltage input to heating rate was examined by heating distilled water to boiling using different voltages. The temperature was monitored and plotted against time and Figure 6 shows that the heating rate is proportional to the voltage input. The higher the voltage input, the faster the water boils. The sharp increase in temperature was observed for higher voltages while a gradual increase was observed at 50 volts. The boiling point of water could be reached in less than 10 minutes at 200-volt setting.

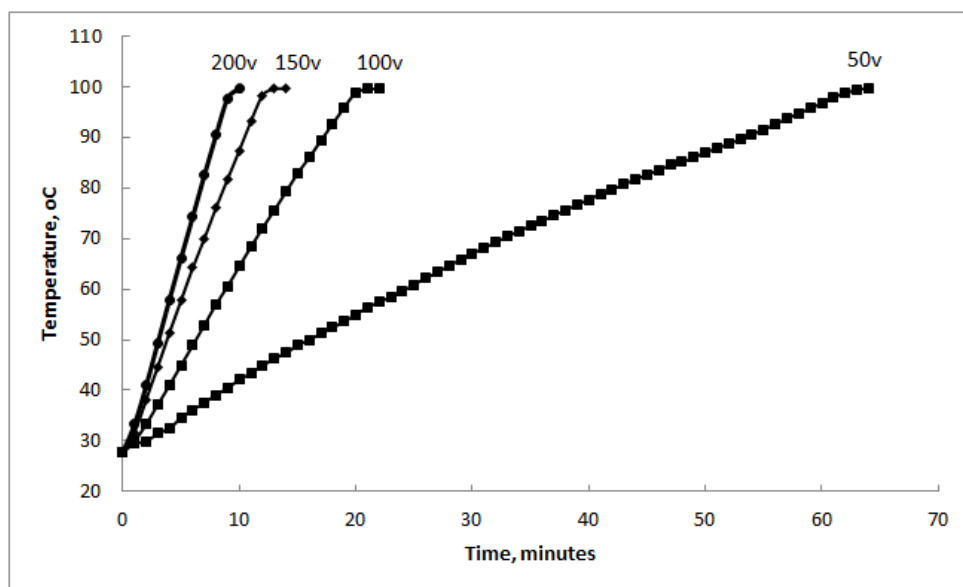

Figure 6. The heating rate of the modified electrothermal cup at different voltages.

Performance of Improvised Pycnometer and Fractional Distillation Lid

The density of an aqueous solution of ethanol varies depending on the amount of alcohol present in the solution. The density of prepared solutions having different concentrations of ethanol was measured using the improvised pycnometer and Figure 7 shows that the density of sample solution decreases as the percentage of alcohol in solution increases. The performance of the improvised pycnometer was found to have a strong correlation ($R = 0.9996$) with standard pycnometer as shown in Figure 8.

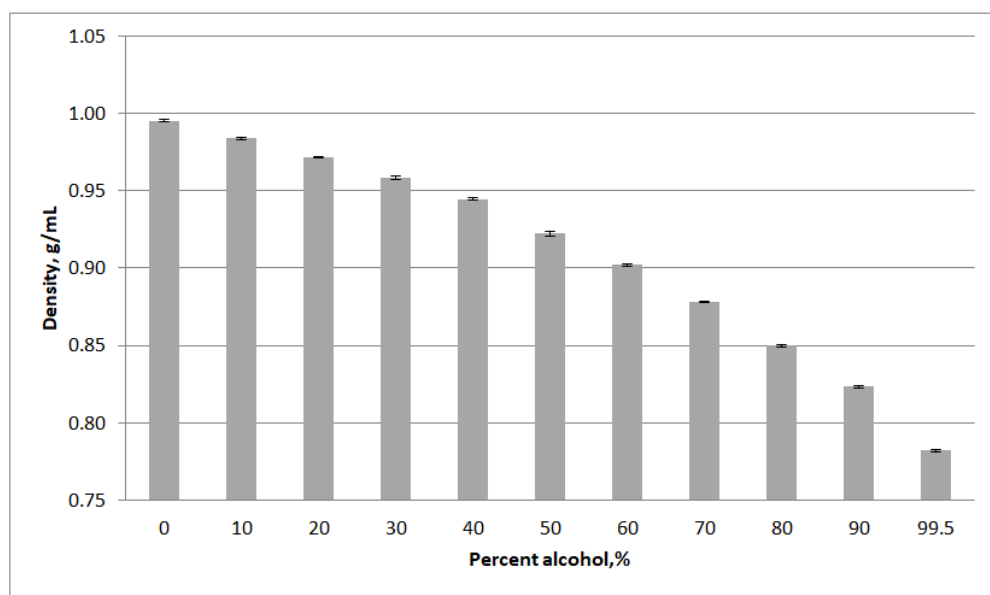

Figure 7. The density of ethanol at different concentrations using improvised pycnometer (number of replicates = 3).

The developed distillation apparatus can be converted easily into any other type of distillation set-up by simply changing the lid. Miscible liquids with a boiling point difference of less than 40°C are efficiently separated by fractional distillation than by simple distillation. The fractional distillation has the effect of several simple distillation processes in a single distillation apparatus and this is achieved with the use of a fractionating column.

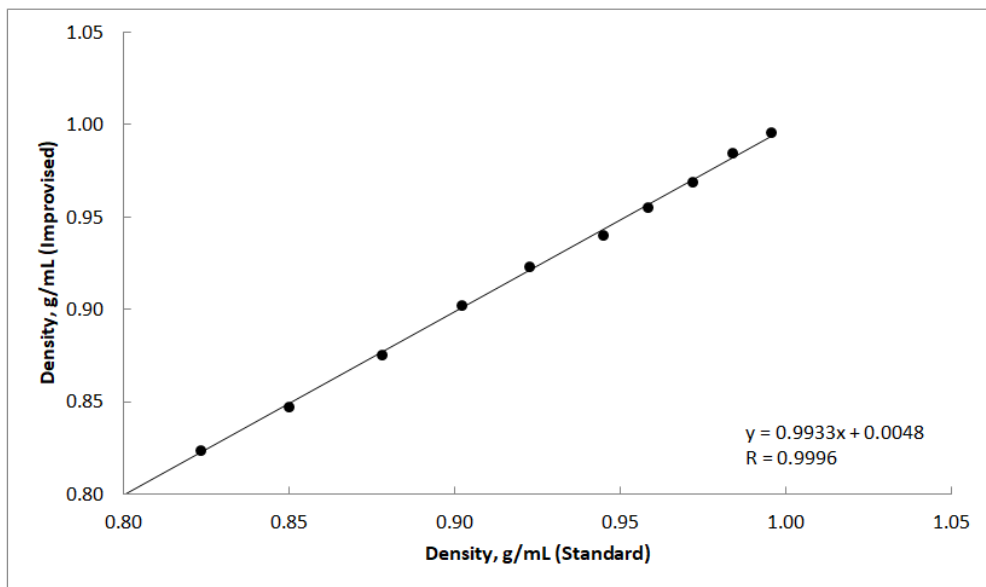

Figure 8. Correlation of density determined using improvised and standard pycnometer for different alcohol concentrations.

Figure 9 shows the distillation plot for different types of column packing placed in a 19-cm long glass column. A column packing made from 15.9 mm glass marble yielded a distillation plot with temperature that continuously increases with the volume of distillate while for column packing made from 11.1 mm glass marble and stainless steel sponge, several fractions were collected first at almost the same temperature before a sharp increase in temperature was observed.

Glass columns having different lengths and filled with 11.1-mm glass marbles were also investigated. Figure 10 shows that temperature increases continuously as the volume of distillate increases for the shortest column while the longer columns demonstrated steady temperature for several volumes of distillates before a sharp increase in temperature was observed.

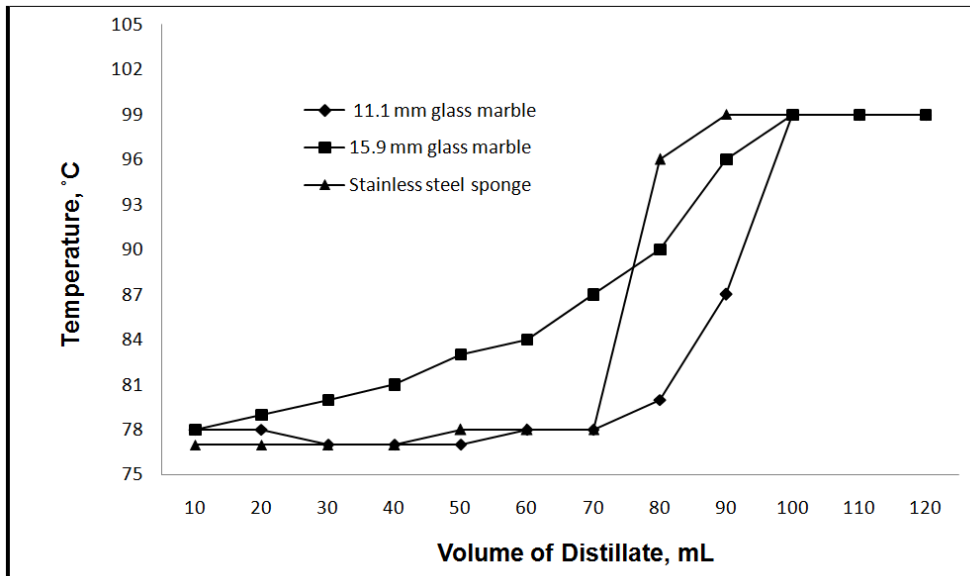

Figure 9. Effect of different types and sizes of column packing on the efficiency of separation of alcohol from sample mixture using 19 cm column (number of replicates = 3).

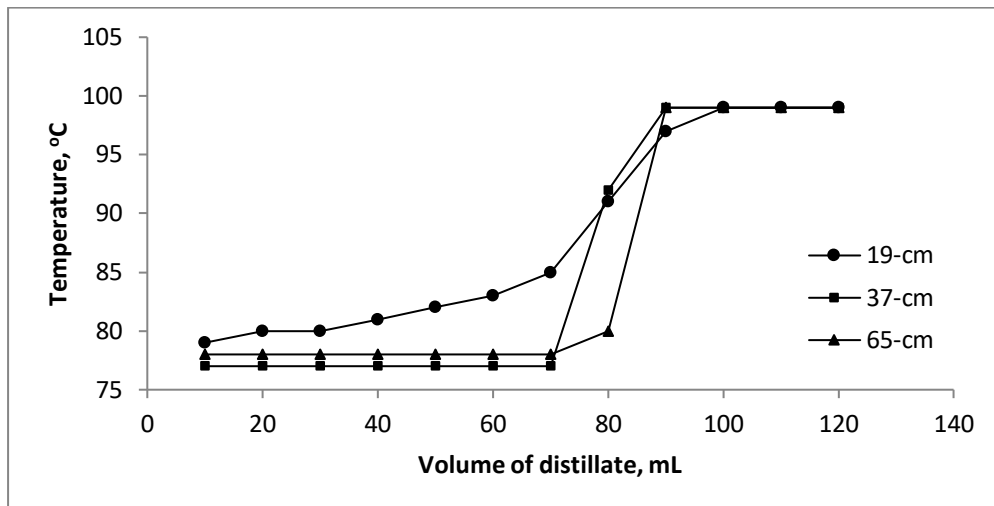

Figure 10. Effect of different lengths of the fractionating column on the efficiency of separation of alcohol from sample mixture (number of replicates =3).

The alcohol content of distillates collected from 65-cm long fractionating column yielded a higher percentage of alcohol than the distillates collected from 37-cm glass column (Figure 11).

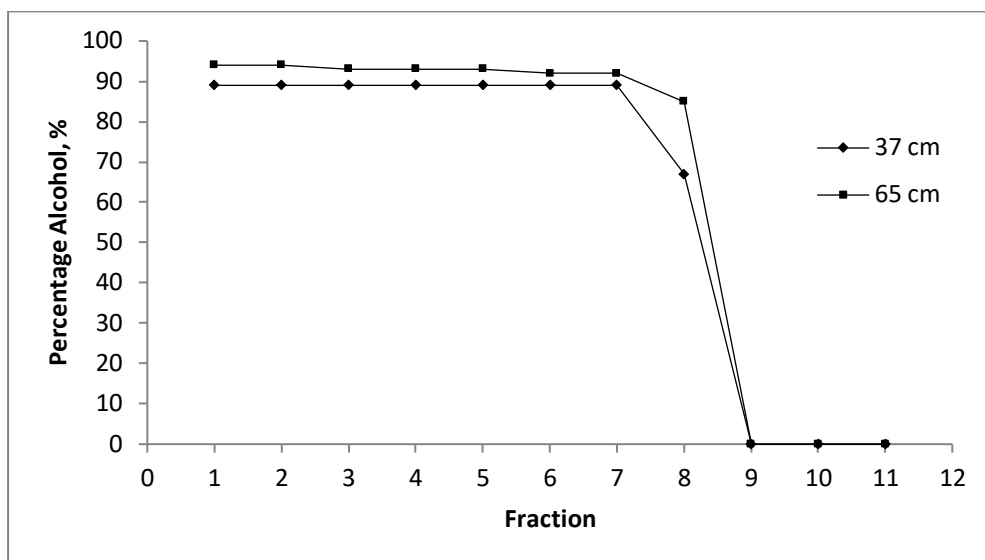

Figure 11. Percentage of alcohol at different fractions collected using different length of glass column (number of replicates = 3).

Performance and Cost of Improvised Distillation Apparatus

Simple distillation. The conductivity of distillates collected from the salt-water mixture by simple distillation set-up was tested using the improvised conductivity tester. Conductivity was observed when the light emitting diodes (LED) in the conductivity tester turned on which indicates the presence of salt in water. Salt-water mixture yielded high conductivity while standard distilled water and distillates collected from improvised and standard set-up for simple distillation produced zero conductivity (Table 2).

Table 2. The conductivity of distillates collected from improvised and standard apparatus for simple distillation.

Sample	Conductivity	
	Improvised	Standard
Salt-water mixture	2	2
Distillate	0	0
Standard distilled water	0	0

Fractional distillation. Figure 12 shows the performance of the improvised apparatus against standard apparatus for fractional distillation. The average density of distillates collected from improvised apparatus ($\bar{x}=0.8056$; $SD=0.0015$; $95\%CI=0.8068, 0.8045$) was lower than the average

density of distillates collected from standard apparatus ($\bar{x}=0.8176$; $SD=0.0024$; $95\%CI=0.8193, 0.8158$).

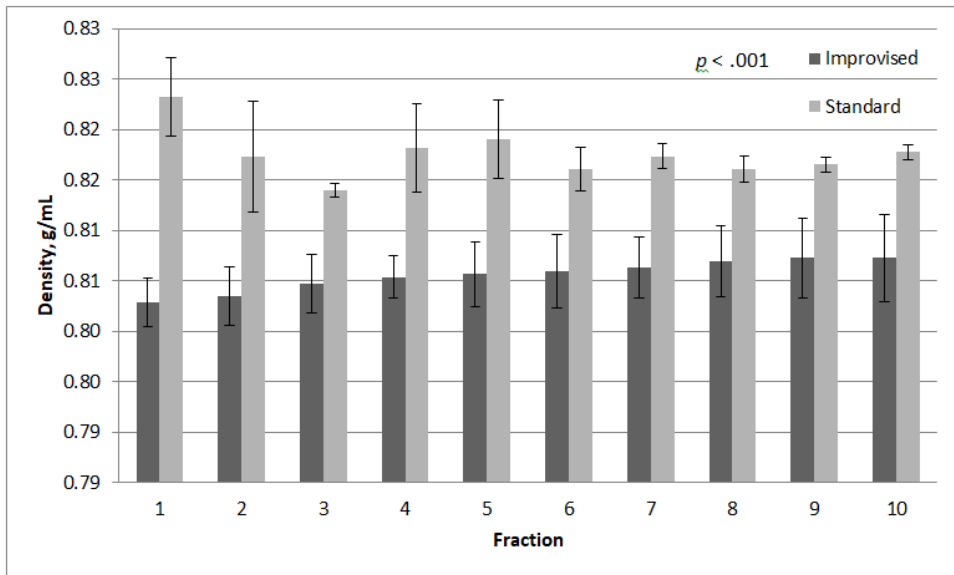

Figure 12. The density of the first ten fractions collected from improvised apparatus ($\bar{x}=0.8056$; $SD=0.0015$; $95\%CI=0.8068, 0.8045$) and standard apparatus ($\bar{x}=0.8176$; $SD=0.0024$; $95\%CI=0.8193, 0.8158$).

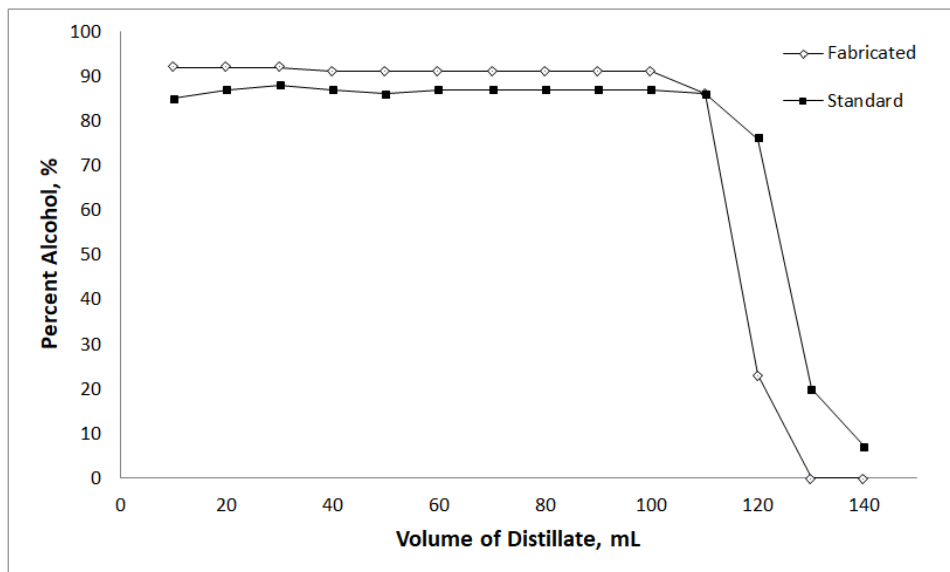

Figure 13. Percentage of alcohol for the first ten fractions collected using improvised and standard (Vigreux) fractional distillation apparatus.

Steam distillation. Steam distillation is used to separate immiscible liquids. It is commonly used to extract essential oils from various plant materials. Since many organic compounds tend to decompose at their boiling point, water is introduced into the distillation apparatus. The water vapor carries small amounts of the vaporized compounds to the collection flask, where the immediate product is a two-phase system of water and the organic distillate, allowing for easy collection. As a proof of concept, the improvised distillation apparatus was used for steam distillation of pomelo peel to extract essential oil. Physical characteristics and percentage yield of essential oil extracted from pomelo peel using improvised and standard distillation apparatus are presented in Table 3.

Table 3. Comparison of essential oils produced from improvised and standard apparatus for steam distillation.

Apparatus	Appearance	Odor	%Yield (\bar{x})	95% Confidence interval, (n=3)
Improvised	Clear	Citrusy	0.56	0.45 - 0.65
Standard	Clear	Citrusy	0.60	0.43 - 0.73

Cost evaluation. The cost for fabrication of one set of improvised distillation apparatus together with the measuring devices is 99% cheaper than purchasing its standard counterpart (Table 4).

Table 4. Cost of improvised distilling apparatus and standard distillation apparatus.

Improvised Apparatus	Cost (PhP)	Standard Apparatus	Cost (PhP)
Modified electrothermal cup, 1 L-capacity with voltage regulator and read-out device	740.00	Heating mantle, 500 ml-cap 500 ml boiling flask (2-neck)	45,900.00 6,900.00
Distilling lid	20.00	Distilling head	5,900.00
Fractionating column filled with column packing	132.00	Fractionating column (Vigreux)	12,500.00
Condenser	52.00	Liebeg condenser	4,900.00
Conductivity tester	50.00	Conductivity meter	21,750.00
Pycnometer	10.00	Pycnometer with thermometer, 50 ml-cap	13,330.00
TOTAL	1,004.00	TOTAL	111,180.00

DISCUSSION

Modified Electrothermal Cup

The modified electrothermal cup served both as the heat source and distillation pot. The light dimmer incorporated into the power plug regulates the voltage input and permits variation on the heating rate. This allows the sample to be heated to its boiling point at a faster rate and regulate the temperature with ease during the distillation process. Unlike the Bunsen burner, the electrothermal cup is safe to use because it does not involve the use of open flame for heating and considering that the temperature controller is not within or near the heat source, the distillation process can be operated at a safer distance. Unlike the conventional distilling flask which is commonly made of glass, the electrothermal cup was made from stainless steel which is not prone to cracks and breakages. It has a wide mouth to facilitate easy cleaning as well as easy charging and discharging of plant materials during steam distillation. The cup was also provided with a plastic handle for easy handling. Further, the modified electrothermal cup could be used for other experiments which would require heating such as melting point and boiling point determination.

Improvised Measuring Devices

It is important to test the sample solution before and after the distillation process to determine its efficiency of separating individual components in a solution. Improvised measuring devices were fabricated to determine the purity of the distillate collected from the distillation process. It further lowers the cost of conducting distillation process in school experiments because it eliminates the use of expensive apparatus and chemicals for testing the purity of the distillates.

Improvised conductivity tester was used to determine the purity of distillates collected from the salt-water mixture using simple distillation set-up while improvised pycnometer was used to determine the purity of ethanol produced from alcoholic beverage using fractional distillation set-up. The conductivity tester presented by Katz and Willis (1994) was modified to have a dual power source. It can be powered either by electricity or by a 9-volt battery. The TRS earphone jack was used instead of copper electrodes to make the distance between the two electrodes constant throughout the experiments.

An improvised pycnometer was used to determine the density of different concentration of ethanol in aqueous solution and density varies as the concentration of ethanol changes. The density of the solutions could be used to determine the concentration of alcohol in the solution by converting it into a concentration unit using a suitable concentration table. The fabricated pycnometer was validated against standard pycnometer and aside from

exhibiting high precision (RSD < 0.04%), it shows a strong correlation ($R = 0.9996$) with standard pycnometer over a range of ethanol concentrations.

Fractionating Column

Efficient separation of an ethanol-water mixture is represented by distillation plot characterized by a relatively stable temperature at which several fractions of distillates were collected and a sharp increase in temperature that reaches a plateau. The lower temperature plateau represents the lower boiling point component of the mixture while the higher temperature plateau represents the higher boiling point component. Distillates collected at the same temperature indicate a relatively pure substance while distillates collected at different temperatures constitute varying amounts of alcohol content as solutions with different concentrations of alcohol have a unique boiling point.

The efficiency of separation for fractional distillation is influenced by the size of the column packing and the length of the fractionating column (Madson 2003; Pavia et al. 2005). Better separation of alcohol was achieved through the use of stainless steel sponge and smaller glass marbles with a diameter of 11.1 mm than the larger glass marbles with a diameter of 15.9 mm. This behavior could be due to the higher surface area available in stainless steel sponge and smaller glass marbles compared to the larger glass marbles. Higher surface area means greater contact between the rising steam and the condensed liquid descending down the column. However, smaller glass marbles were used favorably over stainless steel sponge due to the ease of charging and discharging it from the glass column.

The length of the fractionating column was also found to affect the efficiency of the separation of ethanol from water. Fractional distillation set-up utilizing 65-cm column produced a higher concentration of alcohol than set-up employing 37-cm column and subsequently, the longer column was used throughout the study. The increase in the efficiency of separation could also be attributed to the increase in the evaporation-condensation steps occurring in longer columns (Pavia et al. 2005).

Comparison with Standard Distillation Apparatus

The performance of the improvised apparatus for simple, fractional and steam distillation was compared with standard distillation apparatus. The efficiency of improvised apparatus for simple and steam distillation was found to be comparable with standard apparatus while improvised apparatus for fractional distillation was shown to be more efficient in purifying ethanol from alcoholic beverage than standard apparatus. Figure 12 shows that the improvised apparatus yielded distillates with a lower density (higher concentration of alcohol) and exhibited more reproducible results than the

distillates collected from standard apparatus for the first ten fractions. A paired sample t-test was conducted to compare the performance of improvised and standard apparatus for fractional distillation. The statistical test shows that there was a significant difference between improvised and standard apparatus; $t(9) = -11.00$, $p < .001$. The results suggest that the improvised apparatus is more efficient in separating ethanol from alcoholic beverage and produces more reproducible results than the standard apparatus for fractional distillation that utilizes Vigreux as the fractionating column.

The price of one set of improvised apparatus for simple, fractional and steam distillation was significantly cheaper than the standard apparatus (Table 4). The use of fabricated measuring devices instead of chemicals and reagents to test the purity of the distillates further reduces the cost of experiments involving distillation process. All materials used in the construction of the improvised apparatus are locally available and are easy to replace.

ACKNOWLEDGEMENTS

The study was funded by the Romblon State University through the Research and Extension Office. The comments and suggestions of two anonymous reviewers helped improve this paper.

REFERENCES

- Albert DR, Todt MA and Davis HF. 2012. A low-cost quantitative absorption spectrophotometer. *Journal of Chemical Education*, 89(11): 1432–1435. DOI: 10.1021/ed200829d
- Asheim J, Kvittingen EV, Kvittingen L and Verley R. 2014. A simple, small-scale lego colorimeter with a light-emitting diode (LED) used as detector. *Journal of Chemical Education*, 91(7): 1037–1039. DOI: 10.1021/ed400838n
- Babu KGD, Kaul VK and Ahuja PS. 2002. Portable mini essential oil distillation apparatus. *Journal of Scientific and Industrial Research*, 61(11): 952–960.
- Cao T, Zhang Q and Thompson JE. 2015. Designing, constructing, and using an inexpensive electronic buret. *Journal of Chemical Education*, 92(1): 106–109. DOI: 10.1021/ed500509p
- Cho HC, Kang SA, Choi SI and Cheong C. 2013. Quality characteristics of fruit spirits from a copper distillation apparatus. *Journal of the Korean Society of Food Science and Nutrition*, 42(5): 743–752. DOI: 10.3746/jkfn.2013.42.5.743

- Granger EM, Bevis TH, Saka Y, Southerland SA, Sampson V and Tate RL. 2012. The efficacy of student-centered instruction in supporting science learning. *Science*, 338(6103): 105–108. DOI: 10.1126/science.1223709
- Hosker BS. 2018. Demonstrating principles of spectrophotometry by constructing a simple, low-cost, functional spectrophotometer utilizing the light sensor on a smartphone. *Journal of Chemical Education*, 95(1): 178–181. DOI: 10.1021/acs.jchemed.7b00548
- Katz DA and Willis C. 1994. Two safe student conductivity apparatus. *Journal of Chemistry Education*, 71 (4): 330-331. DOI: 10.1021/ed071p330.
- Kim TK. 2015. T-test as a parametric statistic. *Korean Journal of Anesthesiology*, 68(6): 540–546. DOI: 10.4097/kjae.2015.68.6.540
- Kimel H, Bradley JD, Durbach S, Bell B and Mungarulire J. 1998. Hands-on practical chemistry for all: why and how? *Journal of Chemistry Education*, 75 (11): 1406. DOI: 10.1021/ed075p1406.
- Lancaster S. 2017. How to improve fractional distillation. *Sciencing*. <https://sciencing.com/improve-fractional-distillation-8571855.html>
- Madson PW. 2003. Ethanol Distillation: The Fundamentals. In: Jacques KA, Lyons TP and Kelsall DR (eds). *The Alcohol Textbook*, 4th edition. Nottingham University Press, Nottingham, United Kingdom. pp. 319-336.
- Marinas B. undated. Science and Technology Education in the Philippines. pp. 51-54
<http://www.ibe.unesco.org/curriculum/China/Pdf/IIphilippines.pdf>.
- McDonald JH. 2014. *Handbook of Biological Statistics*. 3rd edition. Sparky House Publishing, Baltimore, Maryland, pp. 180-185.
<http://www.biostathandbook.com/pairedttest.html>
- Muhammad R and Lawal NI. 2015. Improvisation: an alternative approach to solving the problem of ill equipped biology and agricultural science laboratories in senior secondary schools, Nigeria. *The International Journal of Engineering and Science*, 4(5): 1-4.
- Ndirangu M, Kathuri NJ and Mungai C. 2003. Improvisation as a strategy for providing science teaching resources: An experience from Kenya. *International Journal of Educational Development*, 23(1): 75–84. DOI: 10.1016/S0738-0593(01)00054-2
- Padolina MCD and Magno MC. undated. Chemical Education in the Philippines. <http://www.t.soka.ac.jp/chem/CEAP/Philippines.html>.
- Pavia D, Lampman GM, Kriz G and Engell R. 2005. *Introduction to Organic Laboratory Techniques: A Small Scale Approach*. 2nd edition. Thompson Brooks/Cole, United States of America. 100pp.
- Perry RH, Green W and Maloney JO. 1997. *Perry's Chemical Engineers' Handbook*. 7th edition. McGraw Hill. United States of America. 2434pp.
- Singh A, Mehmood Z, Dixit AK, Farooq S and Chhimwal SL. 2016. Medicinal chemistry Indian Herb *Hemidesmus indicus* -A Potential Source of New Antimicrobial Compounds. *Medicinal Chemistry (Los Angeles)*, 612(6): 734–738. DOI: 10.4172/2161-0444.1000422

- Stratakos AC and Koidis A. 2016. Methods for Extracting Essential Oils. In: Preedy VR (ed). Essential Oils in Food Preservation, Flavor and Safety. Academic Press, United States of America. pp. 31–38. DOI:10.1016/b978-0-12-416641-7.00004-3.
- Yoder C, Retterer O, Thomsen M and Hess R. undated. Distillation. Wired Chemist. <http://www.wiredchemist.com/chemistry/instructional/laboratory-tutorials/distillation>
- Wigton BT, Chohan BS, McDonald C, Johnson M, Schunk D, Kreuter R and Sykes D. 2011. A portable, low-cost, LED fluorimeter for middle school, high school, and undergraduate chemistry labs. Journal of Chemical Education, 88(8): 1182–1187. DOI: 10.1021/ed200090r
- Yitbarek S. 2012. Low-cost apparatus from locally available materials for teaching-learning science. African Journal of Chemical Education. 2(1): 32-47.
- Zhilin DM and Kjonaas RA. 2013. Simple apparatus for vacuum filtration. Journal of Chemical Education, 90(1): 142–143.

ARTICLE INFO

Received: 31 January 2018

Revised: 21 December 2018

Accepted: 14 January 14, 2019

Available online: 31 March 2019

Insecticidal potential of Sappan (*Cesalpinia sappan*) seeds ethanol extract against rice weevil (*Sitophilus oryzae*)

Liwayway H. Acero

San Beda University Mendiola Manila

Correspondence: lilyacero1@yahoo.com

<https://doi.org/10.69721/TPS.J.2019.11.1.07>

ABSTRACT

Insects are known not only as pests at home but in agricultural farms as well. There are insects that even destroy the quality of farm harvest and decrease its palatability and marketability. One of the very well-known insect pests is the rice weevil (*Sitophilus oryzae*) which damage the quality of rice grain and lowers its market value. Indigenous plant base environment friendly insecticides are now gaining popularity than commercial insecticides. There are many herbal plants in the Philippines which can be used as potential source of insecticide. One of these is Sappan (*Cesalpinia sappan*) which grows well along riverbanks. The aim of this study was to determine which of the following concentrations (T- control, 0%; T₁, 15%; T₂, 30% and T₃, 45%) of Sappan seed ethanol extract (SSEE) will give the highest mortality in 1.5 h of observation. Experimental research method with four treatments and twenty samples of rice weevils were used to gather pertinent data for this study. Sappan seeds were sundried, chopped, macerated in 95% ethanol for 3 days and subjected to rotary evaporation. Data on mortality for 1.5 h with 15 minutes intervals was analyzed using Analysis of Variance and Fisher Least Significant Difference (LSD) Test as post hoc Test. Results revealed significant difference on the means of four treatments. It is imperative that rice weevils in T₃ (45% of SSEE) had highest mortality in 1.5 h exposure. It implied that SSEE is a potential source of insecticide particularly for rice weevils.

Keywords: rice, herbal, pesticide, tannin

INTRODUCTION

Insect pest like weevil destroys rice grains in storage areas causing decrease in quality and palatability. The use of insecticide from herbal plants in lieu of synthetic insecticide is becoming popular in the market because it will not harm the environment and will maximize the use of herbal plants in the locality. This study explored the potential use of Sappan seeds against rice weevil.

In the Philippines, rice is the main energy source for Filipinos. Most farmers grow rice to supply the staple food for the entire populace. Philippines

being tropical, favor the existence of insect pests not only in their farm but even on their post-harvest facilities like rice granary. Last August 2018, the Philippine government through its National Food Authority imported rice from Thailand and Vietnam. The quality of the said rice was at stake since it was infested with rice weevil (Macatuno and Jaucian 2018). The rice weevil, (*Sitophilus oryzae*) is a small (2.5 to 4 mm), dark brown insect belonging to order Coleoptera and family Curculionide. It has chewing mouthparts at the end of its snout or prolonged head. The adult rice weevil is a dull reddish-brown with round or irregularly shaped pits on the thorax and four light spots on the wing covers. Adult rice weevils live for four to five months and each female lays 300 to 400 eggs during this period. The female uses her strong mandibles to chew a hole in the grain kernel where she deposits a single egg and seals the hole with a gelatinous fluid. Damage to grain caused by this weevil includes reductions in nutritional value, germination, weight and commercial value (Gentry et al. 1991).

One of the herbal trees is Sappan (*Cesalpinia sappan*) locally known as “sibukaw” in the Philippines. This shade loving tree is usually found along the river banks. It is a small to medium-sized shrubby tree, 4-10 m tall; trunk up to 14 cm in diameter; bark with distinct ridges and many prickles, greyish brown; young twigs and hairy buds. Seeds are ellipsoid, flattened, about 18-20 mm x 10-12 mm in size, brown. It is commonly used as a native medicine of the Visayan people (Mariappan et al. 2014).

There are studies using the heartwood and leaves of Sappan as medicinal and anthelmintic agent. Mehrothra and Sharma (1984) stated that “Sappan” is considered a valuable astringent, alterative tonic, emmenagogue, blood purifier and anticoagulant. It strengthens the bones and teeth and is also used in boils and eruptions. The use of Sappan leaves as anthelmintic agent showed that, the leaves can serve as a good natural source of potent antioxidants and anthelmintic medicines (Harjit et al. 2016). Phytochemical screening revealed the presence of flavonoids, phenolic compounds, tannins, saponin, protein, oxalic acid, carbonate, oil and fat. The pods contain 40% tannin. Tannin is found in the leaves, 19%, bark and fruit walls, 44% (Chang et al. 2012).

No published study on the use of its seeds as insecticide, hence this study. This study was conducted mainly to investigate the insecticidal potential of Sappan seeds against rice weevil. The result of this study is beneficial, to partner communities of San Beda University-Institutional Community Involvement Center, where rice farming and selling is the main

source of livelihood. This study aimed to determine the mortality of rice weevils in different concentrations of Sappan seed ethanol extract (SSEE) every 15 minutes observation, for 1.5 h; describe the behavior of rice weevils in different concentration of SSEE every 15 minutes observation; and determine the significant difference on the mortality of rice weevils in different concentrations of SSEE every 15 minutes observation.

METHODS

This study utilized experimental methods, with four treatments and 20 sample insects per treatment. Each treatment was duplicated. T- (control) no SSEE; T₁, 15% SSEE, T₂, 30% SSEE, and T₃, 45% SSEE.

Preparation of Sappan Seed Ethanol Extract (SSEE).

The method of SSEE preparation was patterned from several studies. Sappan premature seeds were sundried for 5 days (Chang et al. 2012). As reported by Elkhalfa et al. (2005) “pods were generally significantly better than bark in their tannin`s contents and the premature pods were always better than the mature ones.” The study of Bourmita et al. (2013), guided the researcher in turning the seeds into smaller parts. Sappan pods were hammered to expose the seeds. Seeds (Figure 1) were chopped using kitchen knife and pounded with the use of mortar and pestle. The study of Tychopoulos and Tyman (1990) served as guide in maceration of ground Sappan seeds to solvent (95% ethanol), which is 1:1.5 weight in grams per volume in milliliter (500 gm of seeds in 750 ml ethanol). The pounded Sappan seeds were soaked in 95% ethanol for 3 days with frequent agitation. The mixture was filtered with the use of cheese cloth and Whatman paper no. 1, and was subjected to rotary evaporation to remove the ethanol (Figure 2).



Figure 1. Pods (left) and seeds (right) of *Cesalpinia sappan* used as insecticide for rice weevils.



Figure 2. Sappan seed ethanol extract (SSEE) in rotary evaporator.

Number of Rice Weevils, per Treatment

To ensure uniformity and avoid bias in the result on the controlled variables, 80 live rice weevils of almost the same size were obtained from the same infested sack of rice from the rice granary of a rice trader in Palanan, Makati City Philippines.

Application of SSEE/Exposure Technique

Rice weevils were exposed to SSEE following the procedures adopted by several insecticidal studies using herbal extracts with slight modifications, (Smith 1979; Gedam and Sampathkumaran 1986; Ahmad and Suliyat 2011; Abbas et al. 2013; Sattar et al. 2014; Edori and Ekpete 2015). Four pairs of sterilized petri dishes (5.5 cm diameter) were used. SSEE was diluted in distilled water, in different concentrations as follows; T1, 15% SSEE, T2, 30% SSEE, and T3, 45% SSEE. The concentration was patterned from the study of Oyedokun et al. (2011) with slight modification. Each filter paper in the bottom of petri dish was applied with concentration of SSEE except for the control

treatment. Infusion was carried out using a syringe. Distilled water was used for control (T-). Ten live rice weevils were subsequently introduced in each petri dish. After which the insects were touched at the abdomen using glass rod to determine its mobility. Mortality in this study is described as non-motility of rice weevils even if touch by glass rod on their abdominal part. Dead rice weevils after 15 minutes of observation were transferred in an empty petri dish, as evident of 15 remaining rice weevils in Figure 3 (sample of observation in T₃ after 30 minutes of observation). Data for the mortality of the rice weevils was recorded every 15 minutes for one and half hour (Aihetasham et al. 2018; Edori and Ekpete 2015).

Data Gathering Procedure

Mortality per treatment and behavior of insects were observed every 15 minutes interval for 1.5 h of observation. Behavior of insects was described based on the study of Edori and Ekpete (2015). Insects were touched by glass rod in the abdominal region. Non motility denotes mortality. Paralyzes denotes movement of the limbs when touch in the abdominal region. Weakening means slow movement in the petri dish.

Data Analysis

Data on mortality was analyzed using single factor Analysis of Variance (ANOVA) and Fisher Least Significant Difference Test as post hoc test (Gomez and Gomez 1984).

RESULTS

Mortality of Rice Weevils per Treatment for 1.5 h Observation

Mortality in this study is described as non-motility of rice weevils even if touched by glass rod on their abdominal part. Table 1 posited the mortality per treatment every 15 minutes of observation. Highest mortality was observed in treatment 3, 100% mortality, followed by T₂, 70% mortality and T₁, with 65% mortality. No mortality was observed in T- (control). Table 2 (Fisher Least Significant Test) revealed significant differences among the four treatments. Significant differences exist between pairs of means with different superscripts as revealed by Fisher LSD (T- vs T₁, T- vs. T₂ and T- vs. T₃). The result further implies that 15% to 45% of SSEE caused death/mortality of the rice weevils in 90 min or 1.5 h but much faster time in T₃. Result revealed 45 %SSEE is more potent than the other treatments.

Table 1. Number of dead rice weevils exposed to different concentrations of SSEE every 15 minutes of observation, Mean values with similar superscript are not significantly different.

Time (minutes)	Treatments			
	- (n=20) 0% SSEE	I (n=20) 15% SSEE	2 (n=20) 30% SSEE	3 (n=20) 45% SSEE
15	0	4	6	6
30	0	4	3	5
45	0	3	2	4
60	0	1	2	5
75	0	1	1	0
90	0	0	0	0
Total	0	13	14	20
Mean	0 ^a	2.166 ^b	2.33 ^b	3.83 ^b

Table 2. Fisher Least Significant Difference Test (Post hoc Test) comparing significant difference among treatment means.

Paired Means	Difference on Paired Means	LSD Value	Analysis
T- ^a vs. T1 ^b	2.166	2.033	significant
T- ^a vs. T2 ^b	2.330	2.033	significant
T- ^a vs. T3 ^b	3.830	2.033	significant
T1 ^b vs. T2 ^b	0.165	2.033	Not significant
T1 ^b vs. T3 ^b	1.664	2.033	Not significant
T2 ^b vs. T3 ^b	1.500	2.033	Not significant

Behavior of Rice Weevils Every 15 Minutes of Observation

Table 3 summarizes the behavior of rice weevils per treatment. On the first 15 minutes, experimental insects are lethargic/weak. Insects moved toward the edge of petri dish (Figure 3). After 30 minutes, insects lie on their back and the legs are still moving. After 45 minutes, remaining insects were totally weak, paralyzed, but still moving if touched by glass rod in their abdomen. All paralyzed insects in T-, T1, T2 and T3 died after 1.5 h of

observation. Dead rice weevil is in bent/crooked position (Figure 4). Rice weevils in negative control (T-) were all active.

Table 3. Behavior of rice weevils exposed to different concentrations of Sappan seeds ethanol extract, for 1.5 hours observation.

Time (min)	Treatments			
	- (0% SSEE)	1 (15% SSEE)	2 (30% SSEE)	3 (45% SSEE)
15	20 were found to be active	16 were found to be weak	14 were found to be weak	14 were found to be weak
30	20 were found to be active	16 lay on their back	17 lay on their back	15 lay on their back
45	20 were found to be active	17 were paralyzed	18 were paralyzed	16 were paralyzed
60	20 were found to be active	19 were paralyzed	18 were paralyzed	15 was paralyzed
75	20 were found to be active	19 were paralyzed	19 were paralyzed	All insects died
90	20 were active	20 were paralyzed	20 were paralyzed	All insects died

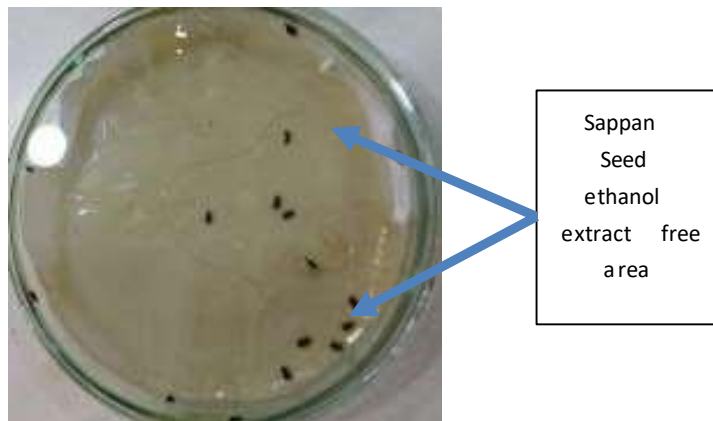

Figure 3. Rice weevils moved to the edge of petri dish (Sappan seed ethanol extract free area) after 15 minutes of exposure to SSEE.



Figure 4. Dead rice weevil (magnified 20 x) in crooked position after 90 minutes of exposure to Sappan seed ethanol extract (SSEE).

DISCUSSION

Mortality of Rice Weevils per Treatment for 1.5 h Observation

Several studies can attest to the mortality of rice weevils in this study. The mortality of the rice weevils may have resulted from the biocidal effects of the plants which contains active components, tannin in particular (Al-Saady 2001). Crude plant extracts cause toxicity (Hiremath and Ahn 1997) and feeding inhibition of insects (Wheeler and Isman 2001). Wu et al. (2011) identified the compound, diterpenoids and flavones in *C. sappan*. Nguyen et al. (2004) isolated a new cassane-type diterpene, named Phangininoxy A (1) and one known Phanginin A (2) from the exact of seeds of *Caesalpinia sappan* Linn. Catherine et al. (2009) stated that effects of higher doses of flavonoids in insects alter normal body functions. The presence of these phytochemical alters some biochemical functions of organisms. The effects of flavonoids on the transhydrogenation, NADH oxidase, and succinate dehydrogenase reactions suggest that compounds of this nature may prove valuable in the control of insect populations by affecting mitochondrial enzyme components. Furthermore, Tran et al. (2015) found out that the compound 3 (phanginin D) is one of the main active components of the seed of *C. sappan* activating caspases-3 which contribute to apoptotic cell death. These studies can attest, to the result of this study, that the premature seeds of Sappan can cause mortality of insects.

Behavior of Rice Weevils Every 15 Minutes of Observation

It can be gleaned from Table 3 that rice weevils were affected by the biochemical components of SSEE. Acero (2017) reported that the insects will tend to evade areas with pungent odor and with tannin content. Edori and Ekpite (2015) reported that “Tannin enters the epidermal tissues of insects

and causes off-feeding of insects thereby affecting its body movements.” The conspicuous/abrupt change in their locomotion is characterized by weakness as early as 15 minutes of exposure to SSEE. After 30 minutes of exposure, paralysis was observed in treatments with SSEE. Touching the abdominal regions of the rice weevils, with glass rod indicates that they are still alive, by movement of the legs even if the insects lie on their back. Paralysis of the entire body except the limbs indicated that the physiologic functions were already disturbed. The paralyzed insects later on die after 1.5 h of observation. Tannin present in Sappan seeds is characterized by astringent, bitter plant polyphenols that either bind and precipitate or shrink proteins. Tannins are astringent (mouth puckering) bitter polyphenols and act as feeding deterrents to many insect pests (War et al. 2012).

Another phytochemical component of Sappan seed is dipentene. It is found in pesticides. It is a colorless liquid with a lemon-like odor, and exposure of insects to dipentene causes allergic contact dermatitis (Rycroft 1980). Dipentene is a known skin and eye irritant. Ingestion of dipentene in insects can irritate the gastro-intestinal tract (Xu et al. 2013). Dipentene also called D-Limonene. Dipentene in human has different effect as reported by Kim et al. (2013), “*d*-Limonene has been designated as a chemical with low toxicity based upon lethal dose (LD₅₀) and repeated-dose toxicity studies when administered orally to animals. In experimental animals and humans, oxidation products or metabolites of *d*-limonene were shown to act as skin irritants. Painting infested rice sacks with SSEE to eradicate rice weevils is suggested.

With the highest mortality in T₃, it is imperative that Sappan seeds can be used as insecticide (rice weevil) at 45% to attain significant result. Studies on the use of Sappan seeds in different concentrations shall be explored on other insect pests.

ACKNOWLEDGEMENTS

The author acknowledges the insights and valuable suggestions and comments of the two anonymous reviewers.

REFERENCES

Abbas M, Shahid M, Iqbal F, Anjum S, Sharif S, Ahmed T and Pirzada T. 2013. Antitermitic activity and phytochemical analysis of fifteen medicinal plant seeds. *Journal of Medicinal Plant Research*, 22(1): 1608-1617.

- Acero LH. 2017. Fresh siam (*Chromolaena odorata*) weed leaf extract in the control of housefly (*Musca domestica*). International Journal of Food Engineering, 3(1): 56-60. DOI: 10.18178/ijfe.3.1.56-61
- Ahmad I and Suliyat T. 2011. Development of fipronil gel bait against german cockroaches, *Blattella germanica* (Dictyoptera: Blattellidae): laboratory and field performance in Bandung, Indonesia. Journal of Entomology, 8(3): 288-294.
- Aihetasham A, Umer M, Akhta MS, Din MI, and Rasib KZ. 2018. Bioactivity of medicinal plants *Mentha arvensis* and *Peganum harmala* extracts against *Heterotermes indicola* (Wasmann) (Isoptera). International Journal of Bioscience, 7(5): 116-126.
- Al-Saady TA. 2001. The effect of some plants extracts on the survival and production of adult of *Callosobruchus maculatus* (Forbicius) (Coleoptera: Bruchidae). MS Agriculture. Basrah University, P.O. Box 49-Basrah Iraq. 85pp.
- Bourmita Y, Cheriti A, Didi M, El Hadj O, Mahmoudi M and Belboukhari N. 2013. Anti-termitic activity of aqueous extracts from Saharan toxic plants against *Anacanthotermes ochraceus*. Journal of Entomology, 10(1): 207-213.
- Catherine C, Jude I and Ngozi I. 2009. Profile of *Chromolaena odorata*. International Journal of Scientific and Research Publication, 3(1): 1-2. DOI: 10.3923/pjn.2009.521.524
- Chang T, Chao S and Ding Y. 2012. Melanogenesis inhibition by homoiso flavavone sappanone A from *Caesalpinia sappan*. International Journal of Molecular Science, 13(8): 10359–10367.
- Edori OS and Ekpete OA. 2015. Phytochemical screening of aqueous extract of *Icacina trichantha* roots and its effect on mortality of wood termites. World Journal of Pharmaceutical Research, 4(10): 213-224.
- Elkhalifa KF, Suliman I and Assubki H. 2005. Variations in tannin's contents of *Acacia nilotica* (L.) Willd. ex Del. in the Sudan. Pakistan Journal of Biological Sciences, 8(1): 1021-1024.
- Gedam P and Sampathkumaran P. 1986. Cashew nut shell liquid: extraction, chemistry and applications. Progress in Organic Coatings, 14(1): 15-157.
- Gomez K and Gomez A. 1984. Statistical Procedures for Agricultural Research. John Wiley and Sons INC. USA. 680pp.
- Gentry JW, Harris KL and Gentry JW Jr. 1991. Microanalytical Entomology Food Sanitation Control. Lithographic Altamonte Springs, Florida. 361pp.
- Harjit K, Amini MH and Suttee A. 2016. Evaluation of antioxidant and anthelmintic properties of *Caesalpinia sappan* L. Leaves. International Journal of Pharmacognosy and Phytochemical Research, 8(2): 362-368.
- Hiremath IG and Ahn YJ. 1997. Parthenium as a source of pesticide. Conference paper, First International Conference on Parthenium management. Dharwad, India, 6(1): 86-89.
- Kim YW, Kim MJ, Chung BY, Bang DY, Lim SL, Choi SM, Lim DS, Cho MC, Yoon K, Kim HS, Kim KB, Kim YS, Kwack SJ and Lee BM. 2013. Safety

- evaluation and risk assessment of *d*-Limonene. *Journal of Toxicology and Environmental Health, Part B*, 16(1): 17-38. DOI: 10.1080/10937404.2013.769418
- Macatuno A and Jaucian MB. 2018. NFA: 330,000 bags of imported rice infested with weevils. <https://newsinfo.inquirer.net/1024529/nfa-330000bags-of-imported-rice-infested-with-weevils#ixzz5g8HyLZzy>. Accessed on 21 February 2019.
- Mariappan K, Ramesh S, Kumar S and Surendar K. 2014. *Caesalpinia sappan* L.: Comprehensive review on seed source variation and storability. *Plant Gene and Trait*, 5(2): 11-21. DOI: 10.5376/pgt.2014.05.0002.
- Mehrotra S and Sharma HP. 1984. Pharmacognostic studies on "Sappan" (*Caesalpinia sappan* Linn.) and its market samples. *Proceedings of the Indian Academy of Sciences - Section A Part 3 Mathematical sciences*, 93(2): 135-150.
- Nguyen M, Awale S, Tezuka T, Tran Q and Kadota S. 2004. Neosappanone A, a xanthine oxidase (XO) inhibitory dimeric methanodibenzoxocinone with a new carbon skeleton from *Caesalpinia sappan*. *Tetrahedron Letters*, 45(1): 8519-8522.
- Oyedokun AV, Anikwe JC, Kelana FA, Mokwunye IU and Azeez OM. 2011. Pesticidal efficacy of three tropical herbal plants' leaf extracts against *Macrotermes bellicosus*, an emerging pest of cocoa, *Theobroma cacao* L. *Journal of Biopesticides*, 4(2): 131-137.
- Rycroft RJ. 1980. Allergic contact dermatitis from dipentene in honing oil. *Contact Dermatitis*, 6(5): 325-329.
- Sattar A, Naeem M and Haq E. 2014. Efficacy of plant extracts against subterranean termites i.e., *Microtermes obesi* and *Odontotermes lokandi* (Blattodea: Termitidae). *Journal of Biodiversity Bioprospecting Development*, 1(2): 122. DOI: 10.4172/2376-0214.1000122
- Smith VK. 1979. Improved techniques designed for screening candidate termiticides on soil in the laboratory. *Journal of Economical Entomology*, 72(1): 877-879.
- Tran M, Nguyen I, Nguyen H, Nguyen T and Phuoung T. 2015. Cytotoxic constituents from the seeds of Vietnamese *Cesalpinia sappan*. *Pharmaceutical Biology*, 53(10): 1549-1554.
- Tychopoulos V and Tyman JHP. 1990. Long-chain phenol- the termal and oxidative deterioration of phenolic lipids from the cashew (*Anacardium occidentale*) nut shell. *Journal of Science, Food, and Agriculture*, 52(1): 71-83.
- Wheeler DA and Isman M. 2001. Antifeedant and toxic activity off *Trichilia americana* et extract against the larvae of *Spodoptera litura*. *Entomologia Experimentalis Applicata*, 98(1): 9-16.
- War AB, Paulraj MG, Amad T, Buhroo AA, Husain B, Ignacimuthu S and Sharma HC. 2012. Mechanisms of plant defense against insect herbivores. *Plant Signaling and Behavior*, 7(10): 1306-1320. DOI: 10.4161/psb.21663

- Wu S, Otero M, Unger F, Goldring F, Phrutivorapongkul A, Chiari C, Kolb A, Viernstein H and Toegel S. 2011. Anti-inflammatory activity of an ethanolic *Caesalpinia sappan* extract in human chondrocytes and macrophages. *Journal of Ethnopharmacology*, 138(2): 364-72. DOI: 10.1016/j.jep.2011.09.011
- Xu Y, Zhang J, Tang C and Ye Y. 2013. A new diterpenoid from the seeds of *Caesalpinia sappan* Linn. *Records of Natural Products*, 7(2): 124-128.

ARTICLE INFO

Received: 06 June 2018

Revised: 15 January 2019

Accepted: 24 February 2019

Available online: June 1, 2019

Road mortality of freshwater turtles in Palawan, Philippines

Alejandro A. Bernardo Jr.

Western Philippines University

San Juan, Aborlan, Palawan

Correspondence: tagwati@gmail.com

<https://doi.org/10.69721/TPS.J.2019.11.1.08>

ABSTRACT

The impact of road mortality on freshwater turtle populations on a global scale could be significant enough to cause the extinction of sensitive species. Essential data on roadkill abundance, composition, spatial patterns, and temporal distribution is needed for crafting mitigation strategies. To provide such information, a survey was conducted along the highway section (67 km) connecting Aborlan and Puerto Princesa City in Palawan, Philippines. Collection of data was done four times a month from January 2010 to December 2015. A total of 127 road-killed turtles belonging to two species of the Geoemydidae family were recorded, 102 (80.3%) of which were classified as the Southeast Asian Box Turtle (*Cuora amboinensis*) and 25 (19.7%) were identified as the Asian Leaf Turtle (*Cyclemys dentata*). The increase in road traffic noticed during the survey period possibly caused the corresponding increase in the roadkill counts of *C. amboinensis*, which is a more common species. Concurrently, the decline in the road-kill counts of *C. dentata* may indicate a severe drop in the population of this less common species. Roadside habitat types, time of the day, and presence of water bodies are found to be important predictors of road-killed turtles. High densities of road-killed turtles clustered in short segments of the road which identified as hotspots. Effective mitigating measures to curve down the impact of road mortality on turtle populations must be implemented and focusing the conservation strategies along the hotspots is considered an efficient and practical option.

Keywords: freshwater turtle, roadkill, road ecology

INTRODUCTION

The continuously expanding road networks traversing across the different terrestrial ecosystems cause considerable habitat degradation and fragmentation. To some extent, paved roads act as a barrier that causes separation of wildlife populations across the habitat fragments. Keyghobati (2007) explained that prolong genetic isolation brought by habitat fragmentation has an overall detrimental effect on the wildlife population. Likewise, the growing number of motor vehicles pose direct threat to wildlife species that cross the roads in search for food, mate, shelter and breeding grounds (Gibbs and Shriver 2002; Ament et al. 2007; Coelho et al. 2008; Glista et al. 2008; Bernardo 2011; Kociolek et al. 2011; Langen et al. 2012; Cook and Blumstein 2013; Crump et al. 2016). In some places where large wild

animals are involved in vehicle collisions, the accidents caused considerable damage to vehicles and sometimes even result in human fatalities. Litvaitis and Tash (2008) suggested that the incidence of a wildlife-vehicle collision is not only a threat to the survival of wildlife population, but is also a concern for human safety, especially if it involved large wildlife species such as deer and moose.

Wildlife roadkill cases are getting more common nowadays. Restaurants offering meals prepared from the meat of road-killed wildlife are gaining popularity in countries where large mammals are involved in vehicle collisions. The increasing number of wildlife mortalities resulting from vehicle collisions also caught the attention of some scientists and conservationists. Some of them investigated the different aspects of road ecology to understand the causes (Cook and Blumstein 2013; Sosa and Schalk 2016), impacts (Coelho et al. 2008; Glista et al. 2008; Kociolek et al. 2011) and to come up with possible mitigating measures that can be implemented to curve down the volume of affected wildlife (Van Manen et al. 2001; Schutt 2008; Ford et al. 2011; Rytwinski et al. 2016).

Among the wildlife species affected by vehicle collisions, freshwater turtles are considered as one of the most frequently affected (Gibbs and Shriver 2002; Steen and Gibbs 2004; Langen et al. 2007; Langen et al. 2012). Being sluggish, turtles are exposed to road traffic much longer as compared to other fast moving wildlife. Moreover, the cryptic coloration of most turtle species makes them less noticeable to drivers, particularly during nighttime.

Turtles are also usually associated with bodies of freshwater (Lim and Das 1999; Diesmos et al. 2008; Schoppe 2008). Thus, the proximity of the road to freshwater habitats such as swamps, ponds, rice fields, streams, and rivers is one of the important predictors of road mortality among turtles (Langen et al. 2012). The high density of turtles crossing along particular road segments and the high number of vehicles passing along the area might result to a high concentration of road-killed turtles on specific locations called hot spots (Langen et al. 2007). Furthermore, they also mentioned that road mortalities along the hotspots might reach a scale that could endanger the local turtle population. Similarly, Gibbs and Shriver (2002) declared that the resulting mortalities from the simulation of turtle movements in areas with many road networks and high traffic volume are high enough to cause substantial population decline in the area.

Road mortality is another addition to the countless threats that greatly affect the turtle population in the wild. Some of the persistent problems that take a significant toll on turtle populations are global warming (Converse et al. 2005), habitat destruction (Sirois et al. 2014), food and medicine trade (Cruz et al. 2007; Diesmos et al. 2008; Schoppe 2008; Krishnakumar et al. 2009) and pet trade (Cruz et al. 2007; Diesmos et al. 2008; Schoppe 2008;

Lyons et al. 2013). The declining trend of the turtle population globally is much alarming as they are poorly studied and are given less conservation priority.

The prospects of developing more road networks soon coupled with the increasing volume of road traffic in places with high biological diversity such as the island of Palawan, highlight the need to study the impact of vehicle-induced mortality to freshwater turtles and other wildlife species as well. Palawan is considered by many as the last frontier in the Philippines because of its pristine environment and unique biological diversity. The province is also endowed with many beautiful tourist spots and abundant natural resources which attract a huge number of tourists and migrants annually. The ballooning population of the province is estimated to be growing at a rate of 2.66% annually (NSO 2013). Developments in the different municipalities resulted in clusters of developed areas in both the southern and northern part of the province. To reach these sprawling developments in the countryside, more road networks are built. Although most of the roads cut across a variety of habitat types such as forest, wetlands, grasslands and mixed agricultural areas, very few studies mentioned the incidence of roadkills in the province (Esselstyn et al. 2004; Tabaranza et al. 2008; Bernardo 2011).

Preliminary investigation of wildlife road mortalities along the national highway in central Palawan revealed an overwhelming number of road-killed bird and mammal species (Bernardo 2011). However, the previous study did not include reptiles particularly freshwater turtles in the report. Hence, the study was conducted to provide baseline information on species composition, relative abundance, spatial patterns, and temporal trends of road-killed turtles. It also identified important predictors of road mortality among freshwater turtles. Finally, road segments with a high number of roadkills were identified as roadkill hotspots. These pieces of information could be used in crafting effective mitigation strategies in the future.

METHODS

Time and Place of the Study

The roadkill survey was conducted in the national highway segment stretching between Puerto Princesa City and the municipality of Aborlan in the province of Palawan, Philippines. The concrete road which spans to about 67 km along the eastern coast of the province served as the transect for the survey. The selected road section traverses different kinds of habitats such as forests, grassland, lowland rice fields, a mixed agricultural area, ponds, creeks, rivers, and streams. The survey was conducted four times a month at regular intervals and lasted from January 2010 to December 2015.

Data Collection

The survey was done on board a motorcycle travelling at a regulated speed of 40 km hr⁻¹. All the freshwater turtles killed by motor vehicles found lying in the road were counted, identified, and the exact locations were determined using a Global Positioning System (GPS) transceiver. Roadside habitat types which are categorized as either forest habitat or open habitat (no trees or very few stranding trees) and the presence of bodies of water were also determined. Data gathering was made early in the morning, to record the nighttime roadkills and another run in the afternoon to record daytime roadkills. Specimens recorded during the morning run were removed from the road to avoid being counted again in the afternoon run. The combined counts of the morning and afternoon run comprised the sample.

Data Analysis

The roadkill data were reported using descriptive statistics, which includes frequency counts and percentages. The relationship between times of the day when the collision happened (daytime and nighttime), and roadside habitat types (forested habitat and open habitat) with the species of road-killed turtles were analyzed using the Chi-square test of independence. Roadkill hotspots were identified based on the abundance and clustering of roadkills along specific road segments.

RESULTS

The only two species of freshwater turtles known to be present in the study area were both recorded during the survey. These are the Southeast Asian Box Turtle (*C. amboinensis*) and Asian Leaf Turtle (*C. dentata*), both of which were members of the Geoemydidae family. A total of 127 road-killed freshwater turtles were recorded during the six years' survey period. Among these, 102 (80.3%) were identified as the Southeast Asian Box Turtle (*C. amboinensis*) while the remaining 25 (19.7%) were identified as the Asian Leaf Turtle (*C. dentata*) (Table 1).

The data clearly show that relatively more *C. amboinensis* individuals were killed by motor vehicles than *C. dentata* annually within the 6-year sampling period. Moreover, the total number of road-killed turtles within the six-year sampling period showed a substantial increase of 26%. However, the observed frequencies of the two recorded species exhibited different trends.

All road-killed freshwater turtles were adults except for one specimen of a juvenile *C. amboinensis*. The sex distribution of the roadkills was not included in the analysis as many samples were crushed, and sex identification becomes difficult and may lead to erroneous results. Roadkills were easily

identified down to species level because of highly recognizable body markings. The *C. amboinensis* can be easily identified by the yellow-green lines marking the head region while the *C. dentata* has unmistakable orange stripes in the head region and the plastron is yellowish brown with many dark-brown stripes (Figures 1 and 2).

Table 1. Abundance of the road-killed turtles recorded in the study area for the sampling years 2010 to 2015.

Turtle Species	Sampling Year						Total	%
	2010	2011	2012	2013	2014	2015		
<i>Coura amboinensis</i>	13	15	14	18	19	23	102	80.3
<i>Cyclemys dentata</i>	6	5	7	4	2	1	25	19.7
Total	19	20	21	22	21	24	127	100



Figure 1. Road-killed Asian Leaf Turtle (*Cyclemys dentata*).



Figure 2. Road-killed Southeast Asian Box Turtle (*Coura amboinensis*).

The frequency of *C. amboinensis* killed by motor vehicles showed a noticeable increase of 77% from 2010 to 2015. In contrast, the frequency of road-killed *C. dentata* exhibits a remarkable decline of 83% within the six sampling years.

The study unfolded that the two species of road-killed turtles were mostly found in road sections with different roadside habitat types. Among the 25 road-killed *C. dentata* that were recorded during the survey, 23 carcasses (92%) were found in road sections near streams with forest cover. Meanwhile, the remaining two specimens (8%) were recorded in the sections of the road with non-forested roadside habitat but closed to slow flowing rocky streams which are connected to the nearby forest in its upstream and downstream sides. On the contrary, most of the *C. amboinensis* carcasses were found in more exposed roadside habitats such as creek, ponds, rice fields, waterlogged grassland, and small exposed streams. Out of the 102 road-killed *C. amboinensis*, 89 carcasses (87%) were found in non-forested roadside habitats. The Chi-square test of the data revealed a significant relationship between the road-killed turtle species and roadside habitat types [$\chi^2(1, N=127)=62.09, p<.05$] (Table 2).

Table 2. Chi-square test for species of road-killed turtles by roadside habitat types [$\chi^2(1, N=127)=62.09, p<.05$].

Species of road-killed turtles	Roadside Habitat Type		Total
	Forested roadside habitat	Non-forested roadside habitat	
<i>Coura amboinensis</i>	13	89	102
<i>Cyclemys dentata</i>	23	2	25
Total	36	91	127

The study also revealed that most of the carcasses found during the survey were accidentally killed during nighttime (1800 to 0600). Out of the total of 127 recorded roadkills, 115 (90.5%) were accidentally killed during the night. Both of the affected species followed a similar pattern. Among the 102 *C. amboinensis* carcasses, 91 (89%) were road-killed during nighttime. Similarly, out of the 25 recorded carcasses of *C. dentata*, 24 (96%) were also road-killed during the night. The Chi-square test of the data revealed a significant relationship between the turtle species and the time of the day when the vehicle collision happened [$\chi^2(1, N=127)=147.41, p<.05$] (Table 3).

Table 3. Chi-square test for species of road-killed turtles by the time of day when the road collision happened [$\chi^2(1, N=127)=147.41, p<.05$].

Species of road-killed turtles	Time of the day when the road collision happened		Total
	Daytime	Nighttime	
<i>Coura amboinensis</i>	11	91	102
<i>Cyclemys dentata</i>	1	24	25
Total	12	115	127

The spatial distribution of road-killed turtles was analyzed by plotting the coordinates of all the spotted roadkills in every one-kilometer segments of the surveyed road using the Global Positioning System (GPS). The results revealed that all the road-killed turtles were found only in 38% of the road segments hence exhibiting a non-random pattern. Moreover, it was also found out that the cases of turtle and vehicle collisions clustered in high densities along specific short segments of the road with nearby bodies of water such as streams, ponds, canals, rice fields, swamps, and waterlogged flats. These

specific road segments with a high density of roadkills were considered as roadkill hotspots for freshwater turtles (Figure 3).

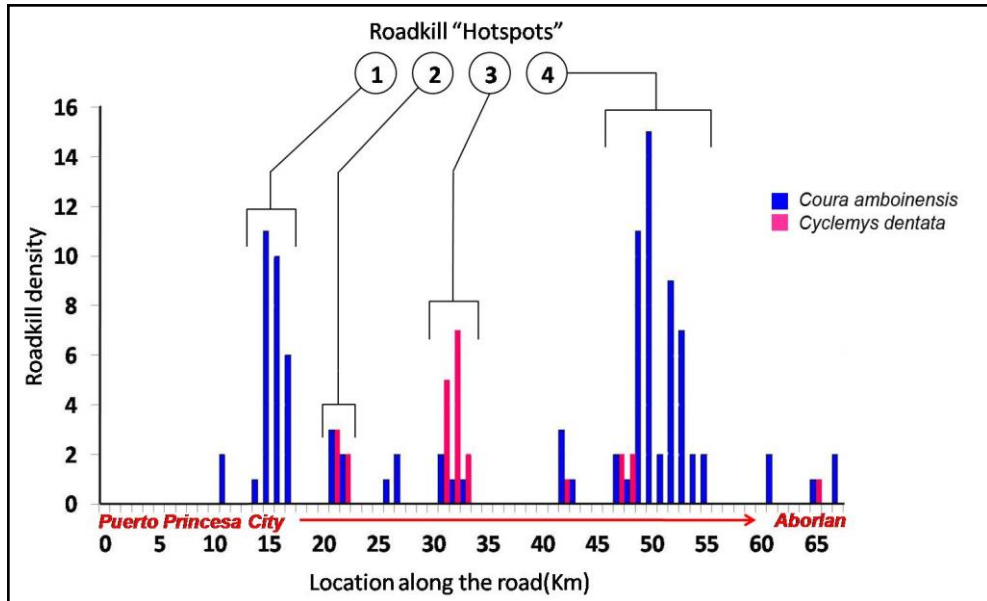

Figure 3. Abundance of road-killed turtles along specific segments of the road connecting Puerto Princesa City and Aborlan in Palawan for sampling years 2010 to 2015.

DISCUSSION

The result of the study revealed that several numbers of freshwater turtles were killed in motor vehicle collisions. Considering the frequency of data collection, the findings of this study only showed a small proportion of the total number of individual turtles affected by vehicle collisions. The annual figure is expected to be much higher if daily roadkills would be accounted.

Out of the four known species of freshwater turtles in Palawan, only two species were recorded in the study area. The roadkill data confirmed the presence of *C. amboinensis* and *C. dentata* in this particular geographic location. Two other freshwater turtles, namely *Dogania subplana* and *Siebenrockiella leytenensis*, which are also known to be found in Palawan (Diesmos et al. 2008) were not recorded in the study area. *Dogania subplana* is commonly found in the southern municipalities of Palawan while the *S. leytenensis* is mostly found in the northern part of Palawan (Diesmos et al. 2008). These species were not found in the study area despite rigorous searching in the roadside habitats.

Within the six years study period, *C. amboinensis* always have higher annual roadkill counts than the *C. dentata*. One of the possible reasons for the disparity of roadkill counts between the two species of turtles is the presence of more *C. amboinensis* individuals in the study area relative to the *C. dentata* (pers. obs.). Diesmos et al. (2008) noted that *C. amboinensis* is a reasonably common species in areas within its habitat range. This species is also known to thrive in a variety of natural and man-made bodies of water (Lim and Das 1999; Diesmos et al. 2008; Schoppe 2008, Schoppe and Das 2011). On the other hand, Diesmos et al. (2008) stated that the *C. dentata* is a relatively less common species that is usually restricted to bodies of water associated in forested habitats and less likely found in altered habitats and man-made bodies of water.

The increasing trend of roadkill incidences involving *C. amboinensis* could be attributed to the increase in the volume of vehicles traversing the road section surveyed. Based on personal observation and accounts of terminal dispatchers, passenger van drivers and police officers manning the checkpoints, a noticeable increase in road traffic were observed within the six-year survey period. The rise in motor vehicles plying the road was primarily contributed by passenger shuttle vans, delivery vans, and new private motor vehicles. This observation concurs with the results of the simulation of collision models done by Litvaitis and Tash (2008) where they asserted that the increasing traffic volume would result to a corresponding increase in the estimated probability of wildlife and vehicle collisions and the risk for slow moving animals such as turtles are considerably higher. However, given that the actual counting of motor vehicles was not included in this study and the roadkill cases of *C. dentata* showed a declining trend, then the impact of traffic volume remains a possible answer that needs to be verified.

Contrariwise, the trend of *C. dentata* roadkill cases declined within the six-year sampling period. One of the possible explanations is that a considerable reduction in the population of *C. dentata* along the roadside habitats could have occurred during the survey period, and it affected the density of the roadkills. The abundance of this turtle species in habitats near the road may not be as many as that of the *C. amboinensis* which can thrive well in man-made habitats (Lim and Das 1999; Diesmos et al. 2008; Schoppe 2008). Several studies in the past attested that high densities of road collisions adversely affected the population of sensitive turtle species (Gibbs and Shriver 2002; Beaudry et al. 2008; Litvaitis and Tash 2008). The difference in size and connectivity of habitats preferred by these species of turtles are also presumed to affect the roadkill patterns. The habitat preference of the *C. dentata* appears to be restricted to areas with bodies of water and have relatively good forest cover. This species usually prefers swamps and small streams with forest vegetation (Diesmos et al. 2008). The distance of separation and lack of connectivity between these streams limit the

replenishment of new individuals, particularly on roadside populations which are severely affected by vehicle collision mortalities.

On the other hand, open wetlands preferred by *C. amboinensis* are usually wide and connected to other wetlands far from the road. In-migration of turtles from adjacent habitats to roadside areas is likely contributing to the stability of *C. amboinensis* population in the roadside habitats. Langen et al. (2012) asserted that the population declines resulting from road mortality would be less if the roadside habitats have high connectedness with other suitable wetland areas because the spillover of individuals moving in from distant habitats will restock the roadside population.

Another point to consider is the habitat modification that took place in some portions of the surveyed road. Within the 6-year sampling period, it was noticed that some portions of the forested roadside habitats underwent agricultural and agroforestry developments. Clearing the roadside forest vegetation could have driven the *C. dentata* turtles in the upstream or downstream part which is already far from the road. This scenario is plausible because, unlike the *C. amboinensis* which prefers many open wetlands, the *C. dentata* is associated with forested streams and does not thrive well in human-altered habitats (Diesmos et al. 2008).

The relatively high incidence of road-killed turtles despite low traffic volume during nighttime is an indication that more turtles cross the road during the night. Although *C. amboinensis* is also active at daytime, the hot road pavement most likely prevented the turtles from crossing the road during the day. Among the 11 recorded *C. amboinensis* killed during the daytime, 10 (91%) were found during rainy or extremely cloudy days wherein the road pavement is relatively cool and wet. The only *C. amboinensis* roadkill specimen recorded during the sunny day was most likely killed in the morning when the temperature of the road pavement is still tolerable. Similarly, the only recorded *C. dentata* which died during daytime was also recorded on a rainy day when the nearby stream was flooded with storm runoff. The flooding of nearby stream might have disturbed and driven the turtle to cross the road. This turtle species is known to be active at night and usually hiding in rocks, sand, gravel, and crevices in the stream banks during daytime (Diesmos et al. 2008). Being active at night might explain why almost all *C. dentata* was killed during nighttime.

The significant relationship between the road-killed turtle species and the roadside habitat types [$X^2(1, N=127)=62.09, p<.05$] and significant relationship between the turtle species and the time of the day when the vehicle collision happened [$X^2(1, N=127)=147.41, p<.05$] strongly suggests that the types of roadside habitats and the time of the day may serve as important predictors of road mortalities among freshwater turtles.

The presence of high density of roadkills in road segments near bodies of water confirmed the dependency of these species of turtles to aquatic habitat (Lim and Das 1999; Diesmos et al. 2008; Schoppe 2008). Moreover, the clustering of roadkills, along certain road, segments strongly suggests that the presence of bodies of water near the road could also be considered an important predictor of road-kill incidences among freshwater turtles. This finding concurs with the observation of Langen et al. (2012) who claimed that the proximity of roads to bodies of water is one of the important predictors of road mortality among three species of freshwater turtles (*Chelydra serpentina*, *Chrysemys picta*, and *Emydoidea blandingii*) in St. Lawrence County, New York State, United States of America.

Identifying the turtle roadkill hotspots is an important baseline in site-specific implementation of conservation efforts (Langen et al. 2012). Focusing the road mortality mitigations along hotspots could be a useful and practical option because it prioritizes high impact areas in much shorter road segments.

The number of roadkills encountered during this study is only a small proportion of the actual number of individuals affected by road mortality. If daily counts were made, the figures could be several folds higher which could be high enough to compromise the effective breeding population size of vulnerable species of turtles in the roadside habitats in the long term (Gibbs and Shriver 2002; Beaudry et al. 2008; Litvaitis and Tash 2008). Also, the exploitation of turtles for food, medicine and pet trade (Gavino and Schoppe 2004; Cruz et al. 2007; Diesmos et al. 2008; Krishnakumar et al. 2009) along roadside habitats could be much higher than in other locations due to the ease of access to the area. Turtles are very slow growing animals which take a considerably longer time before they reach sexual maturity as compared to other vertebrates. Moreover, the matured reproducing individuals lay only a small number of eggs (Ernst et al. 2000).

As a consequence severe exploitation, habitat reduction or alteration, and high incidence of road mortality through time might seriously reduce the sufficient population of these turtles in roadside habitats which may eventually end to localized extinction. Currently, the two species of turtles affected by road mortality accounted in this study are protected by the Philippine Wildlife Act (R. A. 9147). Likewise, both turtles are also listed in the Red List of Globally Threatened Species by the International Union for the Conservation of Nature. The Southeast Asian Box Turtle (*C. amboinensis*) is listed as "Vulnerable" while the Asian Leaf Turtle (*C. dentata*) is listed as "Near-Threatened" (IUCN 2016). The geographic distribution of these turtles is considerably wide, but the anthropogenic activities taking place within their known geographic range are severely affecting the population of these species. Aside from habitat degradation, these turtles are also commonly collected for medicine, food and pet trade (Cruz et al. 2007; Diesmos et al. 2008; Schoppe 2008; Krishnakumar et al. 2009; Lyons et al. 2013). Because of the rampant

illegal trade, both species are listed under Appendix II of the Convention on International Trade of Endangered Species of Wild Flora and Fauna (CITES 2017).

The high volume of road-killed turtles and the increasing trend in the overall roadkill frequency observed in this study suggest that road mortality resulting from vehicle collision is one of the emerging threats to the population of the freshwater turtles living in the roadside habitats. The prospects of road development and the growing traffic volume in Palawan might endanger the existence of these turtles in the long run, particularly the species that already showed a decreasing roadkill count. Moreover, identified predictors of road mortality among freshwater turtles such as types of roadside habitat, presence of bodies of water and time of the day are worth considering in crafting mitigating strategies. Focusing on the implementation of mitigation and conservation efforts on identified roadkill hotspots will ensure its effective and efficient implementation.

This study recommends immediate implementation of effective mitigating measures such as road users' education in the form of billboards, warning signage, and pamphlets. These measures will improve the drivers' awareness, alertness, and behaviour towards crossing turtles and other wildlife as well. Installation of barrier fences or steep concrete ramps and bypass channels are also recommended particularly in hotspot areas. Furthermore, assessment of roadside habitat and habitat fragmentation must also be conducted to understand its impact on turtle populations. Lastly, additional studies on road-killed turtles in the northern and southernmost part of Palawan is also recommended to know if the road mortality also affects the two other species of freshwater turtles, namely *D. subplana* which is found exclusively in Southern Palawan and *S. leytensis* which is found solely in Northern Palawan.

ACKNOWLEDGMENTS

The researcher would like to express his sincerest appreciation to the private lot owners who allowed him to explore the roadside habitats located inside their properties. The author also would like to extend gratitude to all the people who helped during the conduct of the study and for the valuable comments and suggestions of the two anonymous external reviewers that helped improve this paper.

REFERENCES

Ament RJ, Clevenger AT, Yu O and Hardy AR. 2007. An assessment of road impacts on wildlife populations in U.S. National Parks. Western

- Transportation Institute at Montana State University (WTI-MSU) Technical Report REP-07-01. 37pp.
- Bernardo A Jr. 2011. Vehicle-induced mortalities of birds and mammals between Aborlan and Puerto Princesa City National Highway. *The Palawan Scientist*, 5(1): 1-10.
- Beaudry F, de Maynadier PG and Hunter ML Jr. 2008. Identifying road mortality threat at multiple spatial scales for semi-aquatic turtles. *Biological Conservation*, 141: 2550-2563.
- CITES (Convention on International Trade of Endangered Species). 2017. CITES Appendices I, II and III. Convention on International Trade of Endangered Species of Wild Flora and Fauna. www.cites.org/eng/app/appendices.php. Accessed on 3 June 2018.
- Coelho IP, Kindel A and Coelho AVP. 2008. Road kills of vertebrate species on two highways through the Atlantic Forest Biosphere Reserve, Southern Brazil. *European Journal of Wildlife Research*, 54: 689-699.
- Converse SJ, Iverson JB and Savidge JA. 2005. Demographics of an ornate box turtle population experiencing minimal human-induced disturbances. *Ecological Applications*, 15: 2171-2179.
- Cook CT and Blumstein DT. 2013. The omnivore's dilemma: diet explains variation in vulnerability to vehicle collision mortality. *Biological Conservation*, 167: 310-315.
- Crump PS, Stirling JR and Crump RER. 2016. High incidence of road-killed freshwater turtles at a lake in East Texas, USA. *Herpetological Conservation*, 11(1): 181-187.
- Cruz RM, Villafuerte-van den Beukel D, Lacerna-Widmann I, Schoppe S and Widmann P. 2007. Wildlife trade in Southern Palawan, Philippines. *Banwa*, 4(1): 12-26.
- Diesmos AC, Brown RF, Alcalá AC and Sison RV. 2008. Status and distribution of nonmarine turtles of the Philippines. *Chelonian Conservation and Biology*, 7(2): 157-177.
- Ernst CH, Altenburg RGM and Barbour RW. 2000. Turtles of the World. World Biodiversity Series. Biodiversity Center of ETI, ETI/NLBIF. <http://www.nlbif.eti.uva.nl/bis/turtles.php>. Accessed on 12 June 2015.
- Esselstyn JA, Widmann P and Heaney LR. 2004. The mammals of Palawan Island, Philippines. *Proceedings of the Biological Society of Washington*. 117(3): 271-302.
- Ford AT, Clevenger AT, Huijser MP and Dibb A. 2011. Planning and prioritization strategies for phased highway mitigation using wildlife-vehicle collision data. *Wildlife Biology*, 17(3): 253-265.
- Gavino CM and Schoppe S. 2004. First information on the trade of freshwater turtles in Palawan. *Agham Mindanaw*, 2: 53-60.
- Gibbs JP and Shriver WG. 2002. Estimating the effects of road mortality on turtle populations. *Conservation Biology*, 16(6): 1647-1652.
- Glista DJ, DeVault TL and DeWoody JA. 2008. Vertebrate road mortality predominantly impacts amphibians. *Herpetological Conservation and Biology*, 3(1): 77-87.

- IUCN (International Union for Conservation of Nature). 2016. The IUCN Red List of Threatened Species. Version 2016. <http://www.iucnredlist.org>. Accessed on 5 July 2017.
- Keyghobati N. 2007. The genetic implications of habitat fragmentation for animals. *Canadian Journal of Zoology*, 85(10): 1049-1064.
- Kociolek AV, Clevenger AP, St. Clair CC and Proppe DS. 2011. Effects of road networks on bird populations. *Conservation Biology*, 25: 241–249.
- Krishnakumar K, Raghavan R and Pereira B. 2009. Protected on papers, hunted in wetlands: exploitation and trade of freshwater turtles (*Melanochelys trijuga coronata* and *Lissemys punctata punctata*) in Punnamada, Kerala, India. *Tropical Conservation Science*, 2(3): 363-373.
- Langen TA, Gunson KE, Scheiner CA and Boulerice JT. 2012. Road mortality in freshwater turtles: identifying causes of spatial patterns to optimize road planning and mitigation. *Biodiversity and Conservation*, 21(12): 3017-3034.
- Langen TA, Machniak A, Crowe EK, Mangan C, Marker DF, Liddle N and Roden B. 2007. Methodologies for surveying herpetofauna mortality on rural highways. *The Journal of Wildlife Management*, 71(4): 1361-1368.
- Lim BL and Das I. 1999. *Turtles of Borneo and Peninsular Malaysia*. Natural History Publications, Borneo. 151pp.
- Litvaitis JA and Tash JP. 2008. An approach toward understanding wildlife vehicle collisions. *Environmental Management*, 42: 688-697.
- Lyons JA, Natusch DJD and Shepherd CR. 2013. The harvest of freshwater turtles (Chelidae) from Papua, Indonesia, for the international pet trade. *Fauna and Flora International. Oryx*, 47(2): 298-302.
- NSO (National Statistics Office). 2013. Palawan's population increased by 180 thousand. Results of the 2010 Census of Population and Housing. <http://webo.psa.gov.ph/content/palawan%E2%80%99s-population-increased-180-thousand-results-2010-census-population-and-housing>. Accessed on 21 March 2015.
- Rytwinski T, Soanes K, Jaeger JAG, Fahrig L, Findlay CS, Houlahan J, van der Ree R and van der Grift EA. 2016. How effective is road mitigation at reducing road-kill? A meta-analysis. *PLoS ONE*, 11(11). DOI: 10.1371/journal.pone.0166941. Accessed on 3 September 2018.
- Schoppe S. 2008. *Science in CITES: The Biology and Ecology of the Southeast Asian Box Turtle and its Uses and Trade in Malaysia*. TRAFFIC Southeast Asia, Petaling Jaya, Selangor, Malaysia. 56pp.
- Schoppe S and Das I. 2011. *Cuora amboinensis* (Riche in Daudin 1801) – Southeast Asian Box Turtle. In: Rhodin AGJ, Pritchard PCH, van Dijk PP, Saumure RA, Buhlmann KA, Iverson JB, and Mittermeier RA (eds). *Conservation Biology of Freshwater Turtles and Tortoises: A Compilation Project of the IUCN/SSC Tortoise and Freshwater Turtle Specialist Group*. Chelonian Research Monographs No. 5, pp. 053.1–053.13, DOI: 10.3854/crm.5.053.amboinensis.v1.2011, <http://www.iucn-tftsg.org/cbft/>. Accessed on 18 April 2019.

- Schutt P. 2008. Analysis of road kill data from Ankarafantsika National Park, Madagascar. MS Environmental Management, Nicholas School of the Environment and Earth Sciences, Duke University. 36pp. <http://dukespace.lib.duke.edu/dspace/handle/10161/545?show=full>. Accessed on 17 March 2015.
- Sirois AM, Gibbs JP, Whitlock AL and Erb LA. 2014. Effects of habitat alterations on bog turtles (*Glyptemys muhlenbergii*): a comparison of two populations. *Journal of Herpetology*, 48(4): 455-460.
- Sosa R and Schalk CM. 2016. Seasonal activity and species habitat guilds influence road-kill patterns of Neotropical Snakes. *Tropical Conservation*, 9(4): 251-277. DOI: 10.1177/1940082916679662. Accessed on 5 September 2018.
- Steen DA and Gibbs JP. 2004. Effects of roads on the structure of freshwater turtle populations. *Conservation Biology*, 18(4): 1143-1148.
- Tabaranza B, Ruedas L, Widmann P and Esselstyn J. 2008. *Mydaus marchei*. The IUCN Red List of Threatened Species. Version 2014.3. <http://www.iucnredlist.org>. Accessed on 21 March 2015.
- Van Manen FT, Jones MD, Kindall JL, Thompson LM and Scheick BK. 2001. Determining the Potential Mitigation Effects of Wildlife Passageways on Black Bears. In: Irwin CL, Garrett P, McDermott KP (eds), *Proceedings of the 2001 International Conference on Ecology and Transportation*. Center for Transportation and the Environment, North Carolina State University, Raleigh, NC: pp. 435-446. <http://escholarship.org/uc/item/36t6d09p>. Accessed on 20 March 2015.

ARTICLE INFO

Received: 22 November 2018

Revised: 16 May 2019

Accepted: 03 June 2019

Available online: 08 July, 2019

Notes on the first record of *Tridacna noae* (Röding, 1798) (Cardiidae: Tridacninae) in Palawan, Philippines

Krizia Meryl A. Ecube¹, Elmer G. Villanueva¹, Roger G. Dolorosa²,
and Patrick C. Cabaitan³

¹Giant Clam Project, Western Philippines University-Puerto Princesa Campus

²Western Philippines University-Puerto Princesa Campus, Palawan, Philippines

³University of the Philippines Diliman-Marine Science Institute, Quezon City,
Philippines

Correspondence: ecube.km@gmail.com

<https://doi.org/10.69721/TPS.J.2019.11.1.09>

ABSTRACT

The first record of *Tridacna noae* in the province of Palawan, Philippines was documented on June 21, 2018, at Paraiso Resort, Albaguen Island, Port Barton in the municipality of San Vicente. The single specimen measured 4.5 cm in shell length and was partly buried in a massive coral rock. The mantle edge of the species is lined with teardrop-like patches with white margins. This recent finding is an addition to the seven previously reported giant clam species in Palawan and confirms new sighting location in the existing geographic range. The habitat of the species is a semi-protected cove, about 1 m deep at high tide, with massive coral rocks generally covered with the seaweed *Sargassum* spp. Potential threats include the shading effects of macro algae and the constant presence of tourists visiting the resort who might accidentally step on the clams. Buoy demarcation to exclude the area from disturbance may help protect the species and other boring giant clam species. Continued assessment may provide information on the status of *T. noae* in Palawan and in other parts of the country.

Keywords: first record, giant clam, Palawan, Philippines, Port Barton, *Tridacna noae*

The Noah's giant clam, *Tridacna noae* was first described by Röding in 1798 based on the spacing of the scales on the shell, but later, lost its recognition as a distinct species when it was treated as a variant of *Tridacna maxima*. However, the recent use of genetic characterization reaffirmed *T. noae* as a distinct species (Su et al. 2014).

Recent studies show that *T. noae* has a wide geographical distribution range. It extends from the Ryukyu Archipelago in the north to Ningaloo Reef (western Australia) in the south, and from Kiritimati (northern Line Islands) in the east to East Indian Ocean in the west (Borsa et al. 2014; Neo and Low 2017). Its presence in the Philippines has only been alluded by Lizano and Santos (2014) which was later confirmed through published DNA records of specimens from eastern Negros (see Borsa et al. 2014). Viray-Mendoza (2018) recently showed a photo of live *T. noae* from Negros, Philippines and

mentioned that the species can grow up to 40 cm shell length and 9 kg in weight.

The first record of *T. noae* in the province of Palawan, Philippines was documented on June 21, 2018 at Paraiso Resort (10° 29.839' N; 119° 8.790' E), Albaguen Island – one of the several islands in the sheltered bay of Port Barton, municipality of San Vicente in the north-western side of Palawan. The mantle edge of the single specimen is lined by teardrop-like patches with white margins as also shown in Borsa et al. (2014), Neo et al. (2017) and Viray-Mendoza (2018). The clam measured 4.5 cm shell length and was partly buried in a massive coral rock (Figure 1a). Judging from its size and reported maximum shell length, the species could be in its juvenile stage suggesting the occurrence of breeding populations in nearby reefs within the bay. This finding is an addition to the seven previously reported giant clam species in Palawan (Dolorosa et al. 2015), and confirms new sighting location in the existing geographic range. It also suggests connectivity of corridor for dispersal and recruitment of species to Palawan region.

The habitat of this individual is a semi-protected cove, about 1 m deep at high tide, with massive coral substrate generally covered with the brown seaweed *Sargassum* spp. Potential threats include the constant presence of tourists visiting the resort who might accidentally step on it, and the massive growth of *Sargassum* spp. which may cover and deprive the individual of sunlight. Buoy demarcation to exclude the area from disturbance may help protect the species and other boring giant clam species such as *Tridacna crocea* (Figure 1b) and *T. maxima* (Figure 1c and d). Continued assessment may provide information on the status of *T. noae* in Palawan and in other parts of the country.

ACKNOWLEDGEMENTS

This is an offshoot of an on-going research project: Evaluating the status of giant clams in Palawan with funding support from the DOST-PCAARRD project number QMSR—MRRD—MEC-314-1543. We thank the owner of the Paraiso Resort, Heinz and Esperanza Bütikofer for the accommodation and Joy Fusieran, and her family for the support and assistance during the survey. The two anonymous reviewers helped improve the manuscript.

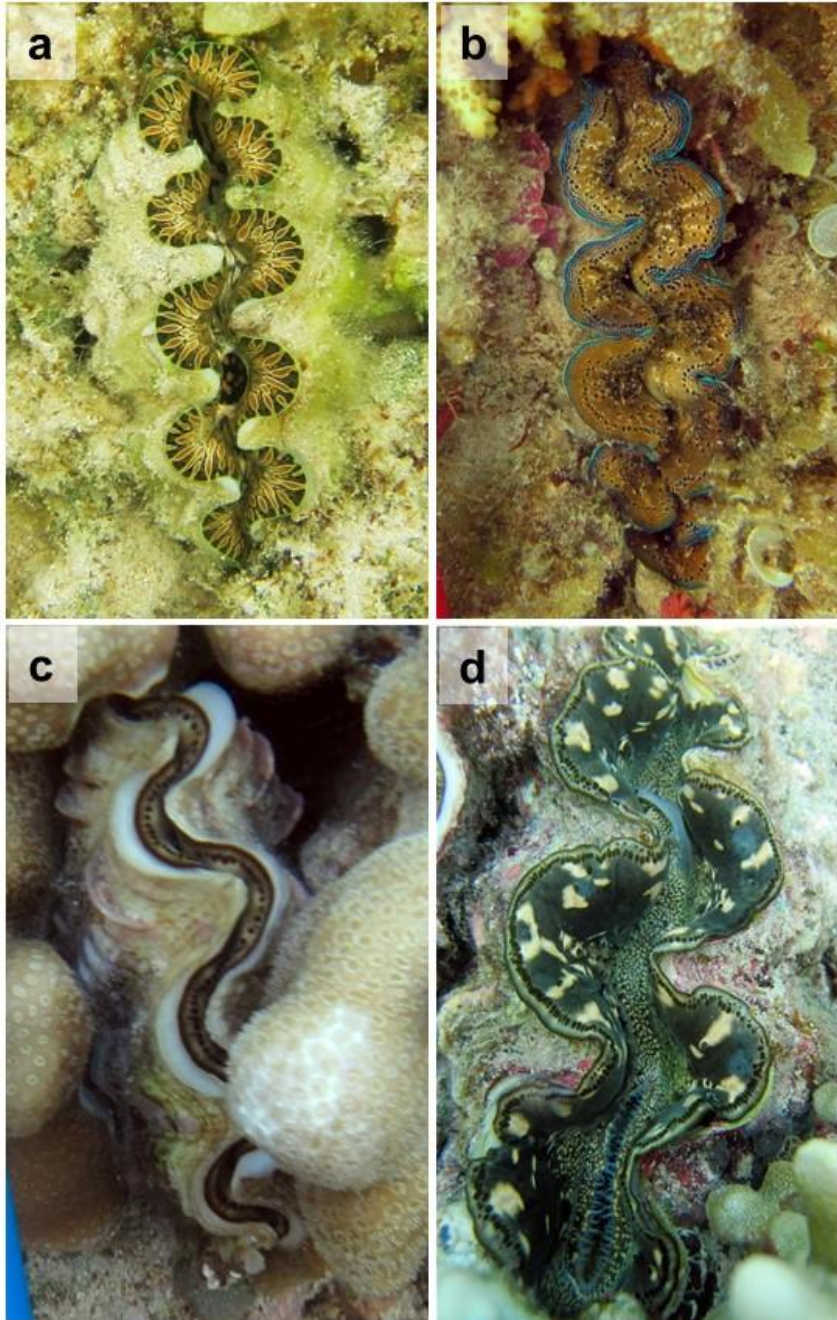

Figure 1. *Tridacna noae*, shell length = 4.5 cm (a), *Tridacna crocea*, shell length = 8.0 cm (b), *Tridacna maxima*, shell length = 4 cm (c) from Albaguen Island, Port Barton, San Vicente, Palawan, Philippines, and *Tridacna maxima*, shell length about 20 cm from Tubтатаha Reefs Natural Park, Cagayancillo, Palawan, Philippines (d).

REFERENCES

- Borsa P, Fauvelot C, Tiavouane J, Grulois D, Rio M, Naguit A, Andrefouet S, Borsa P, Fauvelot C, Tiavouane J, Grulois D, Wabnitz C. 2014. Distribution of Noah's giant clam, *Tridacna noae*. *Marine Biodiversity*, 45: 339–344.
- Dolorosa RG, Picardal RM, Conales SF. 2015. Bivalves and gastropods of Tubbataha Reefs Natural Park, Philippines. *Check List*, 11(1): 1506.
- Lizano AM, Santos MD. 2014. Updates on the status of giant clams *Tridacna* spp. and *Hippopus hippopus* in the Philippines using mitochondrial CO1 and 16S rRNA genes. *Philippine Science Letters*, 7: 187–200.
- Neo ML, Low JKY. 2017. First observations of *Tridacna noae* (Röding, 1798) (Bivalvia: Heterodonta: Cardiidae) in Christmas Island (Indian Ocean). *Marine Biodiversity*. 3pp. DOI: 10.1007/s12526-017-0678-3
- Neo ML, Wabnitz CCC, Braley RD, Heslinga GA, Fauvelot C, Wynsberge S VAN, Andrefouet S, Waters C, Tan AS-H, Gomez ED, Costello MJ, Todd PA. 2017. Giant clams (Bivalvia: Cardiidae: Tridacninae): A comprehensive update of species and their distribution, current threats and conservation status. *Oceanography and Marine Biology: An Annual Review*, 55: 87–388.
- Su Y, Hung J-H, Kubo H, Liu L-L. 2014. *Tridacna noae* (Röding, 1798) – a valid giant clam species separated from *T. maxima* (Röding, 1798) by morphological and genetic data. *Raffles Bulletin of Zoology*, 62: 124–135.
- Viray-Mendoza V. 2018. The giant clams in the Philippines. *The Maritime Review*. The online edition of the Maritime League's Maritime Review Magazine. 1–10. Accessed on 14 August 2018. <http://maritimereview.ph/2018/05/18/the-giant-clams-in-the-philippines/>

ARTICLE INFO

Submitted: 27 July 2018

Revised: 14 September 2018

Accepted: 17 September 2018

Available online: 27 September 2018

Role of Authors: KMAE, EGV, and RGD: gathered the data, and wrote and revised the manuscript. PCC: wrote and revised the manuscript.

Guide for Authors

Introduction

The Palawan Scientist, a recipient of the CHED's Journal Incubation Grant, is an annual peer-reviewed multi-disciplinary journal published by the Western Philippines University, with its main campus in Aborlan, Palawan, Philippines. It accepts original research papers, reviews, notes and short communications in agriculture, fisheries and aquatic sciences, environment, education, engineering, mathematics, sociology and other discipline.

Regular papers should report the results of original research which have not been previously published elsewhere, except in preliminary form. Review articles should cover specific topics which are of active current interest. Notes (Technical Note or Short Communication) should be brief descriptions of experimental procedures, technical operations or applied activities within the laboratories or in the field.

Indexing

Emerging Sources Citation Index (Clarivate Analytics) http://mjl.clarivate.com/cgi-bin/jrnlst/jlresults.cgi?PC=MASTER&Word=*palawan%20scientist

ASEAN Citation Index <https://www.asean-cites.org/index.php?r=home>

Philippine E-Journals <https://ejournals.ph/issue.php?id=1081#view>

Google Scholar

ASFA (under evaluation)

Publication Fees

This journal does not charge any publication fee.

Copyright

The author should include a statement in the cover letter that once the article is accepted, the copyright is transferred to the publisher, the Western Philippines University.

Ethics and malpractices

The submitted articles are only sent to reviewers, and only accepted articles are posted in the website. The reviewer has no authority to distribute the draft manuscript. The use of photos from the internet or from other published works is not allowed unless a written permission from the publisher or copyright holder is presented. Authors caught plagiarizing or giving false information about the status of submitted articles will be banned from submitting articles to the journal.

Author Contributions

For articles with two or more authors, it is required to indicate the contributions of each author which may include but not limited to the following: conceptualization, fund sourcing, data collection, conduct of experiment, manuscript writing.

Changes to authorship

Any change (deletion or addition) to authorship should be made before the publication of the article. To request such change, the corresponding author should email the editor and state the reasons. A confirmation from the added or deleted authors must be also received by the editor.

Referees

The corresponding author must submit, together with the manuscript, the names and contact details (including the link to the reviewer's publications) of at least four potential external Reviewers. However, the Editors reserve the right with regard to the selection of external reviewers.

Cover letter and Certification

The author should submit together with the manuscript a cover letter which explains the papers' contribution to the body of knowledge. The author must also submit a certification that the article has not been published before except in a form of abstract in conference proceedings; that the same article is not consideration for publication in any language elsewhere; that there is no conflict of interests among authors, and or funding agencies; that all authors have approved its submission in the Palawan Scientist Journal; that all authors will transfer the copyright to the publisher (Western Philippines University) upon the acceptance and publication of the article; that the article will not be published in any form or language without the consent of WPU.

Checklist

1. Before submission, please make a final checking of the manuscript using this summary of the Guide for Authors.
2. Name, postal address, email and phone numbers of Corresponding author should be included in the manuscript
3. Names, affiliations and email addresses of at least four external reviewers should be provided.
4. To facilitate the tracking of the progress of the article, the file name of the manuscript should be "Family Name_First Name of Corresponding Author_Version 1. (for example, Cruz_John_Version 1). (Eventually, the file name of the manuscript with comments from the internal reviewer should be "MS Number_Cruz_John_Version 2", and the next version from the author should be labelled as "MS Number_Cruz_John_Version 3...).
5. The font of the manuscript is Georgia, size 11; in A4 size paper with 2.54 cm margin on both sides with page numbers at the center of the bottom of each page; in MS word file, double spaced, single column with line numbers.
6. Tables and Figures with stand-alone captions are placed at the end of the manuscript
7. The photos (if there are, should be at least 300dpi) were included in the manuscript using the "Insert Pictures" tool of the MS word. A separate file of each photo is available upon request.
8. Permission has been obtained for use of copyrighted materials from other sources.
9. The word count for regular and review papers does not exceed 5000 words.
10. The Results is separate from the Discussion section
11. Only authors mentioned in the text are also the ones mentioned in the References and vice versa. The role of each author is indicated
12. Provision of a cover letter (in pdf or jpg file with signature of the corresponding author) explaining why the submitted manuscript deserves to be published. For multiple authored manuscript, the role of each author has been indicated in the cover letter.
13. A certification that the manuscript has not been published in any language nor considered for publication in other journals should be submitted together

with the manuscript. The certification should also include a statement that there is no conflict of interests among authors or funding agencies, and all authors have agreed to the contents of the paper and shall transfer the copyright to the Western Philippines University upon the publication of the article.

14. The manuscript has been spelled checked, and grammar checked.
15. The referencing style of the *Palawan Scientist* has been strictly followed

Manuscript Submission (Regular Research Article)

1. Authors must submit an e-copy of manuscript in **Microsoft Word** through the "Submit Article" panel of the website. Although English is the official language of *The Palawan Scientist*, researches written in Filipino and other indigenous Filipino dialects (with English Abstract) are most welcome.
2. Received articles will be properly acknowledged and will be immediately sent off for review if it satisfies the preliminary review made by the member(s) of the Editorial Board. If it does not satisfy the preliminary review, it will be sent back to the corresponding author for revision. No paper will be sent for review unless it strictly follows the format in this **Guide for Authors**.
3. The corresponding author should submit by email the following files:
 - Tables in MS Word or MS Excel
 - Graphs or photos in PDF or JPEG files (high resolution, at least 300 dpi)

Manuscript Preparation

1. The manuscript should be no more than 5,000 words; typewritten using Georgia, font 11; double-spaced, single column, justified on A4 (8.3"x11.7") size paper, with 2.54 cm margins on all sides. All pages should be numbered consecutively at the center of the bottom of the page. Line numbers should be continuous (do not restart at each page).
2. Page 1 should contain the following: title of the article, running title, author(s), affiliation(s), name and complete contact details (mailing address, telephone number, fax number, and e-mail address) of the person to whom correspondence should be sent. A superscript in Arabic numbers should be placed after the author's name as reference to their affiliations. The title of the paper should be centered, **bold** and written in a sentence form. Capitalize only the first word of the title and proper nouns if there are. Scientific name(s) when included in the title should be italicized and not enclosed in parenthesis.
3. Page 2 should contain a short abstract of not more than 250 words. The abstract should contain facts and conclusions, rather than citation of the areas and subjects that have been treated or discussed. It may start with the hypothesis or a statement of the problem to be solved, followed by a description of the method or technique utilized to solve the problem. It should end with a summary of the results and their implications. The abstract is to be followed by a maximum of six **Keywords**.
4. The paper (regular research article) should be organized with the following main headings: **ABSTRACT, INTRODUCTION, METHODS, RESULTS, DISCUSSION, ACKNOWLEDGEMENTS, REFERENCES**. First subheadings should be in **bold** with each main word capitalized (example: **Study Site**). For second sub-headings, the first letter of the first word should be capitalized. Paper written in other formats will not be accepted or sent for

review, instead it will be returned to the author for revision. **Notes** may have an **abstract**, followed by the **notes, acknowledgements** and **references**. **Review papers** may contain an **abstract, introduction**, the **different headings of the sub-topics, acknowledgements** and **references**.

Figures and Tables

1. Figures and tables should be numbered (Arabic numerals) chronologically. Captions for figures and tables should be double spaced and have justified margins; First line not indented. The use of text box for figure and table captions is discouraged.
2. References to the tables and figures in the text should be cited as: Table 1; Figure 1; Tables 1 and 2; Figures 1 and 2. Photos, maps and drawings should be treated as Figures.
3. The Table or Figure should be placed at the end of the manuscript or could be submitted in separate file.
4. Figures must be in black and white if possible with a background free from major grid lines (of y-axis); the x and y axes are labeled and legend is provided.
5. Illustration should be original line drawings of good quality and should not exceed A4 size paper. Inscriptions should be readable even if the drawing is reduced by 75%. Drawings should be scanned and saved in TIF or PDF format before embedding on the manuscript. Separate file of the photos/illustrations may be requested upon the acceptance of the manuscript.
6. Photographs – if possible, all photos used in the paper must have been taken by the author(s). Photos taken by other researchers/individuals/organizations must be duly acknowledged in the paper. The use of photos downloaded from the web/internet is strictly forbidden unless a written permission from the copyright holder (of that photo) is presented.

Scientific, English and Local Names

1. All organisms must be identified by their English, scientific names and local names if possible.
2. Scientific names must be cited for all organisms at first mention. Subsequently, only the initial of the genus should be written except when starting a sentence with a scientific name. All scientific names should be italicized. Example: *Tectus niloticus*; *Anadara* sp. *Musa* spp. Do not italicize the higher levels of taxonomic classification (example: family Echinometridae).
3. Local names should be in double quotes (example: locally called “saging” not ‘saging’; “palay” not ‘palay’).
4. Research articles dealing on species list should provide the authorities for each species (example: *Conus magus* Linnaeus, 1758; *Enosteoides philippinensis* Dolorosa & Werding, 2014).

Punctuations

1. Unfamiliar terms, abbreviations, and symbols must be defined/spelled out at first mention.
2. Mathematical equations should be clearly presented so that they can be interpreted properly. Equation must be numbered sequentially in Arabic numerals in parentheses on the right-hand side of the equations.

3. Numbers lesser than 10 should be spelled out (for example: eight trees, 10 fish) except when followed by a unit of measure (for example: 9 cm, not nine cm). Numbers should be spelled-out when starting in a sentence (example: Nine fishermen were...).
4. No apostrophes in years (example: 2014s not 2014's)
5. No periods in acronyms (example: UNESCO not U.N.E.S.C.O.; CITES not C.I.T.E.S.)
6. Write dates in this manner: day-month-year (example: 20 October 2012 or 20 Oct 2012).
7. Use the International System of Units of measurements. Separate the value and the unit of measure (example: 5 mm, 25 g, 30 m³, 100 μm, 9 ind ha⁻¹, 10 sacks ha⁻¹, 2 kg h⁻¹ day⁻¹). To fix a single space between the value and its unit of measure, use the MS word command “CTR+SHIFT+SPACE BAR” to provide a space between the value and its unit of measure.
8. Do not separate a percent sign with the number (example: 5%, 30%).
9. Use 24-h system for time (example: 13:00 instead of 1:00 pm). To express a measured length of time, abbreviations for hour (h), minutes (min) and seconds (sec) will be used (example: 2 h and 30 min; or 2.5 h).
10. Use a single capital letter when writing latitude and longitude (example: 9°44'27.80"N and 118°41'2.01"E).
11. Compass points (north, south, east, west) and their derivations (northern, southern, eastern, western) are lowercased (example: north of Palawan) except when they form part of the place name (example: South Cotabato; Eastern Samar).

References

1. References to the literature citations in the text should be by author and year; where there are two authors, both should be mentioned; with three or more authors, only the first author's family name plus “et al.” need be given. References in the text should be cited as:
 - Single author: (Frietag 2005) or Freitag (2005)
 - Two authors: (De Guzman and Creencia 2014) or De Guzman and Creencia (2014)
 - More than two authors: (Sebido et al. 2004) or Sebido et al. (2004).
2. Use a semi-colon followed by a single space when citing more than two authors. Arrange by date of publication with the latest being the last in the list (example: Sebido et al. 2004; Freitag 2005; De Guzman and Creencia 2014).
3. Use a comma followed by a single space to separate citation of different references authored by the same author (example: Jontila 2005, 2010). If the same author and year are cited, use a “letter” to distinguish one paper over the other (example: Creencia 2010a,b).
4. Alphabetize authors with the same year of publications. Use semi colons to separate each publication (example: Balisco and Babaran 2014; Gonzales 2014; Smith 2014).
5. Write journal's name in full (examples: The Palawan Scientist, not Palawan Sci; Reviews in Fisheries Science, not Rev. Fish. Sci.).
6. The list of citation at the end of the paper should include only the works mentioned in the text and should be arranged alphabetically.
7. Citing journal articles– name(s) and initial(s) of author(s), year, full title of research article (in sentence form), name of the journal (not abbreviated),

volume number, issue number (if given), range of page numbers, DOI number (if available) and/or web link:

Dolorosa RG, Grant A and Gill JA. 2013. Translocation of wild *Trochus niloticus*: prospects for enhancing depleted Philippine reefs. *Reviews in Fisheries Science*, 21(3-4): 403-413. DOI: 10.1080/10641262.2013.800773.

Jontila JBS, Balisco RAT and Matillano JA. 2014. The sea cucumbers (Holothuroidea) of Palawan, Philippines. *AAFL Bioflux*, 7(3): 194-206. <http://www.bioflux.com.ro/docs/2014.194-206.pdf>

8. Citing of books – name(s) of author(s), year of publication, full title of the Book (capitalize each main word), publisher, place of publication and total number of pages.

Gonzales, BJ. 2013. *Field Guide to Coastal Fishes of Palawan*. Coral Triangle Initiative on Corals, Fisheries and Food Security, Quezon City, Philippines. 208pp.

9. Citing a chapter in a book – name(s) of author(s), year, full title of the chapter in a book (capitalize each main word), last name of editor and title of book, edition, publisher, place of publication and page range of that chapter:

Poutiers JM. 1998. Gastropods. In: Carpenter KE and Niem VH (eds). *FAO Species Identification Guide for Fishery Purposes. The Living Marine Resources of the Western Central Pacific Seaweeds, Corals, Bivalves and Gastropods*. Food and Agriculture Organization, Rome, pp. 364-686.

10. Citing a Webpage – names of the author (s), year, Title of the article, webpage address and date accessed.

Morrison H and Pfuetzner S. 2011. Australia Shells. <http://www.seashells.net.au/Lists/TEREBRIDAE.html>. Accessed on 4 September 2011.

CITES (Convention on International Trade of Endangered Species. 2014. The CITES Appendices. Convention on International Trade in Endangered Species of Wild Flora and Fauna. www.cites.org. Accessed on 5 January 2014.

11. Citing a thesis or dissertation – author's family name, initial names of the author, year, title of the thesis, degree, name of institution, address of the institution, total number of pages (pp).

Guion SL. 2006. Captive breeding performance of *Crocodylus porosus* (Schneider 1901) breeders at the Palawan Wildlife Rescue and Conservation Center. BS in Fisheries. Western Philippines University-Puerto Princesa Campus, Palawan, Philippines. 28pp.

Lerom RR. 2008. Biosystematics study of Palawan landraces of rice (*Oryza sativa* L.). Doctor of Philosophy, Institute of Biological

Sciences, University of the Philippines-Los Baños College, Laguna, Philippines. 197pp.

12. Citing a Report

Picardal RM and Dolorosa RG. 2014. Gastropods and bivalves of Tubbataha Reefs Natural Park, Cagayancillo, Palawan, Philippines. Tubbataha Management Office and Western Philippines University. 25pp.

13. In Press articles when cited must include the name of the journal that has accepted the paper.

Alcantara LB and Noro T. In press. Growth of the abalone *Haliotis diversicolor* (Reeve) fed with macroalgae in floating net cage and plastic tank. Aquaculture Research.

14. Citing an article from an online newspaper.

Cuyos JM. 2011. Endangered deep-sea shells seized from Mandaue firm. Inquirer Global Nation, Cebu. <http://globalnation.inquirer.net/cebudailynews/news/view/20110325-327558/Endangered-deep-sea-shells-seized-from-Mandaue-firm>. Accessed on 31 May 2012.

The Palawan Scientist

www.palawanscientist.org

Volume 11, 2019

Western Philippines University
San Juan, 5302 Aborlan, Palawan
www.wpu.edu.ph

Review Paper	Page
Backyard farming of tilapia using a biofloc-based culture system Christopher Marlowe A. Caipang and Arlene L. Avillanosa	1
Original Articles	
Molecular characterization and tissue distribution of cysteamine dioxygenase (ADO) in common carp <i>Cyprinus carpio</i> Maria Mojena Gonzales-Plasus, Yutaka Haga, Hidehiro Kondo, Ikuo Hirono and Shuichi Satoh	17
Spatial and temporal distribution, Size composition, and Abundance of Oval squid, <i>Sepioteuthis lessoniana</i> (Lesson 1830) in the coastal waters of Bolong, Zamboanga City, Philippines Jesus Rolando A. Samson	29
<i>Elysia leucolegnote</i> (Opisthobranchia: Sacoglossa) Jensen 1990, a new record for the Verde Island Passage, Philippines Katherine P. Sanchez-Escalona	42
Perspectives on outcome-based education among faculty members teaching business courses at a Philippine university Teresita F. Pepito	49
Development of an improvised convertible distillation apparatus for teaching and learning chemistry Henley Fontamillas Galiga	65
Insecticidal potential of Sappan (<i>Cesalpinia sappan</i>) seeds ethanol extract against rice weevil (<i>Sitophilus oryzae</i>) Liwayway H. Acero	85
Road mortality of freshwater turtles in Palawan, Philippines Alejandro A. Bernardo Jr.	97
Notes	
Notes on the first record of <i>Tridacna noae</i> (Röding, 1798) (Cardiidae: Tridacninae) in Palawan, Philippines Krizia Meryl A. Ecube, Elmer G. Villanueva, Roger G. Dolorosa, and Patrick C. Cabaitan	112